

REFACTORING ROUTER SOFTWARE TO  
MINIMIZE DISRUPTION

ERIC ROBERT KELLER

A DISSERTATION

PRESENTED TO THE FACULTY  
OF PRINCETON UNIVERSITY  
IN CANDIDACY FOR THE DEGREE  
OF DOCTOR OF PHILOSOPHY

RECOMMENDED FOR ACCEPTANCE  
BY THE DEPARTMENT OF  
ELECTRICAL ENGINEERING  
ADVISER: JENNIFER REXFORD

NOVEMBER 2011

© Copyright by Eric Robert Keller, 2011.

All rights reserved.

# Abstract

Network operators are under tremendous pressure to make their networks highly reliable to avoid service disruptions. Yet, operators often need to change the network to upgrade faulty equipment, deploy new services, and install new routers. Unfortunately, changes cause disruptions, forcing a trade-off between the benefit of the change and the disruption it will cause. This disruption comes from the very design of the routers and routing protocols underlying the Internet's operation. First, since the Internet is composed of many smaller networks, in order to determine a path between two end points, a distributed calculation involving many of the networks is necessary. Therefore, during any network event that requires a calculation, there will be a period of time when there are disagreements among the routers in the various networks, potentially leading to the situation where there is no path available between some end points. Second, selecting routes involves computations across millions of routers spread over vast distances, multiple routing protocols, and highly customizable routing policies. This leads to very complex software systems. Like any complex software, routing software is prone to implementation errors, or *bugs*. Given these disruptions, operators must make tremendous effort to minimize their effect. Not only does this lead to a lot of human effort, it also increases the opportunity for mistakes in the configuration – a common cause of outages.

We believe that with a refactoring of today's router software we can make the network infrastructure more accommodating of change, and therefore more reliable and easier to manage.

First, we tailor software and data diversity (SDD) to the unique properties of routing protocols, so as to avoid buggy behavior at run time. Our bug-tolerant router executes multiple diverse instances of routing software, and uses voting to determine the output to publish to the forwarding table, or to advertise to neighbors. We designed and implemented a router hypervisor that makes this parallelism transparent

to other routers, handles fault detection and booting of new router instances, and performs voting in the presence of routing-protocol dynamics, without needing to modify software of the diverse instances.

Second, we argue that breaking the tight coupling between the physical and logical configurations of a network can provide a *single*, general abstraction that simplifies network management. Specifically, we propose VROOM (Virtual ROuters On the Move), a new network-management primitive where virtual routers can move freely from one physical router to another. We present the design, implementation, and evaluation of novel migration techniques for virtual routers with either hardware or software data planes.

Finally, we introduce the concept of router grafting. This capability allows an operator to rehome a customer with no disruption, compared to downtimes today measured in minutes. With our architecture, this rehoming can be performed completely transparently from the neighboring network – where the customer’s router is not modified and is unaware migration is happening.

Together, these three modifications enable network operators to perform the desired change on their network without (i) possibly triggering bugs in routers that causes Internet-wide instability, (ii) causing unnecessary network re-convergence events, (iii) having to coordinate with neighboring network operators, or (iv) needing an Internet-wide upgrade to new routing protocols.

## Acknowledgements

First and foremost, I would like to thank my family. To my wife, Kristen, I might have been crazy to do this, but you were there supporting me every step of the way. To my children, Braden and Devin, you amaze me each and every day. Maybe you'll read this one day when you're older and understand what I was doing all those years. And to my mom, your strength helped push me to finish what I started.

I will be forever indebted to my advisor, Jennifer Rexford. She gave me the space I needed to be creative, the guidance I needed to do great work, and provided me with the tools to be a great researcher for life. I cannot find the words to express how amazing of a person she is. To work with her was such a great experience and I feel very fortunate that I had this opportunity. I can only hope to help future students like she has helped me.

I would like to thank my committee for their great help in completing this dissertation – Kobus van der Merwe, Matthew Caesar, Ruby Lee, and Mung Chiang. Kobus and Matt were also significant contributors and mentors in the technical direction of this dissertation (Kobus on the VROOM and Grafting work and Matt on the Bug-Tolerant Router work). Their insight, knowledge, and guidance were invaluable. Ruby and I worked closely together on research that falls outside of the scope of this dissertation. She taught me a great deal about security and has gotten me very excited about the field.

I would also like to thank other direct contributors to this dissertation – Minlan Yu, Yi Wang, and Michael Schapira. Not only did collaborating with them directly help this dissertation, but they are great people and it was a pleasure working with each of them.

I would also like to thank Andy Bavier, Mike Freedman, and Rob Harrison for their incredible feedback on the many things I've worked on at Princeton. I credit Andy for teaching me a lot about how to write a paper. And I would similarly like

to thank Jakub Szefer for our work together on NoHype. We pushed though and achieved something great with that.

I came to Princeton after seven years working for Xilinx. I owe a lot to Phil James-Roxby (who actually proof read all of my papers at Princeton), Gordon Brebner, and Steve Guccione for being great friends and mentors, even after I left. Having three great people to lean on over the years helped a lot (from deciding to go back to school, to applying, to pushing through those middle years of the Ph.D. when the initial excitement has worn off but there is still a long time left).

Similarly, grad school wouldn't be grad school without my fellow students. I would like to thank my friends in the electrical engineering and computer science departments and in particular the rest of the Cabernet group (past and present). It was great fun knowing them and learning from them.

And finally, I would like to thank Intel for the fellowship during my final year.

I dedicate this dissertation to the memory of my dad, Robert Keller.

He was the one who introduced me to computers at a young age – going all the way back to the TRS-80. I wish he could have been here to see me finish, but I'm thankful he at least got to see me start.

# Contents

Abstract . . . . .	iii
Acknowledgments . . . . .	v
List of Tables . . . . .	xiii
List of Figures . . . . .	xiv
<b>1 Introduction</b>	<b>1</b>
1.1 Change Happens . . . . .	2
1.1.1 Equipment Failure . . . . .	3
1.1.2 Planned Maintenance of Equipment and Software . . . . .	4
1.1.3 Updated Inter-domain Policy and Connectivity . . . . .	4
1.1.4 Changes to Optimize Resource Utilization . . . . .	6
1.1.5 Service Deployment and Evolution . . . . .	7
1.2 Change is Painful . . . . .	8
1.2.1 Because Routing Software is Distributed . . . . .	8
1.2.2 Because Routing Software is Complex . . . . .	9
1.2.3 Because Routing Software is Configurable . . . . .	11
1.3 Refactoring Router Software . . . . .	12
1.4 Router Trends . . . . .	15
<b>2 Hiding Routing Software Bugs from Adjacent Routers with the Bug-Tolerant Router</b>	<b>20</b>

2.1	Introduction . . . . .	20
2.1.1	Challenges in dealing with router bugs . . . . .	20
2.1.2	The case for diverse replication in routers . . . . .	22
2.1.3	Designing a Bug-Tolerant Router . . . . .	23
2.2	Software and Data Diversity in Routers . . . . .	24
2.2.1	Diversity in the software environment . . . . .	25
2.2.2	Execution environment diversity . . . . .	29
2.2.3	Protocol diversity . . . . .	30
2.3	Bug Tolerant Router (BTR) . . . . .	31
2.3.1	Making replication transparent . . . . .	31
2.3.2	Dealing with the transient and real-time nature of routers . . . . .	34
2.4	Router Hypervisor Prototype . . . . .	36
2.4.1	Wrapping the routing software . . . . .	37
2.4.2	Detecting and recovering from faults . . . . .	38
2.4.3	Reducing complexity . . . . .	39
2.5	Evaluation . . . . .	41
2.5.1	Voting in the presence of churn . . . . .	42
2.5.2	Processing overhead . . . . .	47
2.5.3	Effect on convergence . . . . .	48
2.6	Discussion . . . . .	50
2.7	Related Work . . . . .	52
2.8	Summary . . . . .	54
<b>3</b>	<b>Decoupling the Logical IP-layer Topology from the Physical Topology with VROOM</b>	<b>55</b>
3.1	Introduction . . . . .	55
3.2	Background . . . . .	59
3.2.1	Flexible Link Migration . . . . .	59

3.2.2	Related Work . . . . .	61
3.3	Network Management Tasks . . . . .	63
3.3.1	Planned Maintenance . . . . .	63
3.3.2	Service Deployment and Evolution . . . . .	64
3.3.3	Power Savings . . . . .	65
3.4	VROOM Architecture . . . . .	66
3.4.1	Making Virtual Routers Migratable . . . . .	67
3.4.2	Virtual Router Migration Process . . . . .	69
3.5	Prototype Implementation . . . . .	73
3.5.1	Enabling Virtual Router Migration . . . . .	74
3.5.2	Realizing Virtual Router Migration . . . . .	77
3.6	Evaluation . . . . .	79
3.6.1	Methodology . . . . .	79
3.6.2	Performance of Migration Steps . . . . .	81
3.6.3	Data Plane Impact . . . . .	82
3.6.4	Control Plane Impact . . . . .	86
3.7	Migration Scheduling . . . . .	88
3.8	Summary . . . . .	89
<b>4</b>	<b>Seamless Edge Link Migration with Router Grafting</b>	<b>91</b>
4.1	Introduction . . . . .	91
4.1.1	A Case for Router Grafting . . . . .	92
4.1.2	Challenges and Contributions . . . . .	94
4.2	BGP Routing Within a Single AS . . . . .	97
4.2.1	Protocol Layers: IP, TCP, & BGP . . . . .	97
4.2.2	Components: Blades, Routers, & ASes . . . . .	99
4.3	Router Grafting Architecture . . . . .	100
4.3.1	Copying BGP Session Configuration . . . . .	101

4.3.2	Exporting & Resetting Run-Time State . . . . .	103
4.3.3	Migrating TCP Connection & IP Link . . . . .	105
4.3.4	Importing BGP Routing State . . . . .	106
4.4	Correct Routing and Forwarding . . . . .	108
4.4.1	Control Plane: BGP Routing State . . . . .	108
4.4.2	Data Plane: Packet Forwarding . . . . .	110
4.5	BGP Grafting Prototype . . . . .	111
4.5.1	Configuring the Migrate-To Router . . . . .	112
4.5.2	Exporting Migrate-From BGP State . . . . .	112
4.5.3	Exporting Migrate-From TCP State . . . . .	113
4.5.4	Importing the TCP State . . . . .	113
4.5.5	Migrating the Layer-Three Link . . . . .	114
4.5.6	Importing Routing State . . . . .	115
4.6	Optimizations for Reducing Impact . . . . .	115
4.6.1	Reducing Impact on eBGP Sessions . . . . .	115
4.6.2	Reducing Impact on iBGP Sessions . . . . .	117
4.6.3	Eliminating Processing Entirely . . . . .	118
4.7	Performance Evaluation . . . . .	119
4.7.1	Grafting Delay and Overhead . . . . .	119
4.7.2	Optimizations for Reducing Impact . . . . .	121
4.8	Traffic Engineering with Grafting . . . . .	124
4.8.1	Traffic Engineering Today . . . . .	124
4.8.2	Migration-Aware Traffic Engineering . . . . .	125
4.8.3	Practical Considerations . . . . .	128
4.8.4	The Max-Link Heuristic . . . . .	129
4.8.5	Experimental Results on Internet2 . . . . .	130
4.8.6	Migration Improves Network Utilization . . . . .	131

4.8.7	Frequent Migration is Not Necessary . . . . .	134
4.8.8	Only a Fraction of Links Need to be Migrated . . . . .	135
4.9	Related Work . . . . .	137
4.10	Summary . . . . .	139
<b>5</b>	<b>Conclusion</b>	<b>140</b>
5.1	Summary of Contributions . . . . .	140
5.2	A Unified Architecture . . . . .	143
5.3	Future Work . . . . .	146
5.3.1	Monitoring in Addition to Voting for a Bug-Tolerant Router . . . . .	146
5.3.2	Hosted and Shared Network Infrastructure with VROOM . . . . .	146
5.3.3	Router Grafting for Security . . . . .	147
5.4	Concluding Remarks . . . . .	148
	<b>Bibliography</b>	<b>149</b>

# List of Tables

2.1	Example bugs and the diversity that can be used to avoid them. . . .	26
3.1	The memory dump file size of virtual router with different numbers of OSPF routes . . . . .	82
3.2	The FIB repopulating time of the SD and HD prototypes . . . . .	82
3.3	Packet loss rate of the data traffic, with and without migration traffic	85
4.1	Summary of notation used in model of traffic engineering with migration.	126
4.2	Comparison of the improvement over the original topology optimized for routing only when performing grafting at different intervals (over 7 days traffic). . . . .	135

# List of Figures

1.1	Generic diagram of a router design. . . . .	3
1.2	Generic network of networks consisting of end users and autonomous systems. . . . .	5
1.3	Generic network consisting of routers and links. . . . .	7
1.4	Router software architecture. . . . .	10
1.5	Router software refactoring. . . . .	18
1.6	Router trends. . . . .	19
2.1	Architecture of a bug-tolerant router. . . . .	32
2.2	Implementation architecture. . . . .	37
2.3	Effect of bug duration on fault rate, holding bug interarrival times fixed at 1.2 million seconds. . . . .	43
2.4	Effect of bug interval on fault rate, holding bug duration fixed at 600 seconds. . . . .	43
2.5	Effect of voting on update overhead. . . . .	46
2.6	Effect of convergence time threshold. . . . .	46
2.7	BTR pass-through time. . . . .	48
2.8	Network-wide simulations, per-router convergence delay distribution. . . . .	49
3.1	Link migration in the transport networks . . . . .	59
3.2	The architecture of a VROOM router . . . . .	67

3.3	VROOM’s novel router migration mechanisms (the times at the bottom of the subfigures correspond to those in Figure 3.4)	67
3.4	VROOM’s router migration process	69
3.5	The design of the VROOM prototype routers (with two types of data planes)	74
3.6	The diamond testbed and the experiment process	79
3.7	The Abilene testbed	81
3.8	Virtual router memory-copy time with different numbers of routes	81
3.9	Delay increase of the data traffic, due to bandwidth contention with migration traffic	85
4.1	Migration protocol layers.	97
4.2	Migrating the session with X between route processor blades (from RP1 to RP2).	100
4.3	Migrating session with A between routers (from B to C).	101
4.4	Router grafting mechanisms – migrating a session with Router A (not shown) from router Migrate-from to router Migrate-to. The boxes marked bgpd and network stack are the software programs. The boxes marked <i>RIB<sub>A</sub></i> , <i>config<sub>A</sub></i> , and <i>TCP<sub>A</sub></i> are the routing, configuration, and TCP state respectively.	102
4.5	A topology where AS 200 has migrate-from router A, migrate-to router B, internal router F, and external routers C, D, and G, and remote end-point E.	107
4.6	The router grafting prototype system.	111
4.7	BGP session grafting time vs. RIB size.	120
4.8	The CPU utilization at the migrate-to router during migration, with a 200k prefix RIB.	121
4.9	Updates sent as a result of migration.	122

4.10	Network model for traffic engineering with migration. . . . .	126
4.11	Evaluation of max-link for a single 5-minute period. . . . .	132
4.12	Evaluation of max-link over 7 days of traffic – time-series. . . . .	134
4.13	Evaluation of max-link over 7 days of traffic – cumulative distribution function. . . . .	134
4.14	Fraction of traffic each user node sends in an example 5-minute period.	136
4.15	Cumulative distribution function of the number of links that need to be migrated during each interval over 7 days of traffic (2016 5-minute intervals). Shown are three lines corresponding to different thresholds – only links in the top X% of traffic are migrated. . . . .	137
5.1	Unified architecture. . . . .	143

# Chapter 1

## Introduction

The Internet has become an integral part of our lives. Not only do many of us have high speed connections at our homes, we also have data connections on our mobile devices as well as work at businesses that provide or rely on software accessible across a network. In order to be able to visit a website, use a web service, or use any distributed software, the underlying infrastructure must provide reachability, and more specifically the Internet as a whole must provide global reachability – i.e., any networked device can communicate with any other networked device, so long as those networked devices are not explicitly blocking the communication. To provide this global reachability, the elements in the network infrastructure (i.e., the routers) communicate with one another to determine the paths to take to reach each destination. Any change to the underlying infrastructure, such as adding new equipment or performing maintenance on the existing equipment, causes the routers to determine a new set of paths. Given the expansiveness of the Internet, changes are continually occurring. Not only do these changes cause transient disruptions while new paths are determined but they can also cause longer term disruptions where some destinations are unreachable for an extended period. For the most part, the current Internet does a reasonably good job at minimizing disruptions thanks to the tireless effort of the

many network operators. Moving forward, this task will be increasingly difficult as (i) the size of the Internet grows, and (ii) applications which have more significant demands in terms of availability, such as remote health care and a smart power grid, become more common. We believe that with a refactoring of today's router software we can make the network infrastructure more accommodating of change, and therefore more reliable and easier to manage. In this chapter we first present some background on the network management tasks necessary to operate a network (Section 1.1) and the disruption that the associated changes in the network infrastructure can cause (Section 1.2). We then detail our proposal to refactor router software in order to accommodate these changes without disruption (Section 1.3). We wrap up with a discussion of some recent trends in router design that enable this refactoring that is seemingly impossible to realize in practice (Section 1.4).

## 1.1 Change Happens

To many, the Internet can be represented as a big cloud on a diagram connecting end users of some service (e.g., a web site) to the servers that host that service. Of course, in reality, the Internet is a federation of thousands of independently controlled networks. To determine how to reach a particular destination, the network elements known as routers essentially communicate with one another (both within the same network and between neighboring networks) to disseminate information about available paths.

These routers are in constant communication as the Internet is constantly changing. Each individual network often undergoes some changes during the normal course of operation. To understand the different types of change, in this section, we overview several reasons for change.

### 1.1.1 Equipment Failure

As routers are physical, electronic equipment, the components within them are susceptible to failure. Routers have several important components, as shown in Figure 1.1. The interface cards have the connectors to the actual cables along with custom hardware to process each packet (e.g., decide which output port to forward the packet on). The switching fabric, which is many times multiple cards, provide a high bandwidth and low latency connection between each of the line cards. The route processors run the software that computes the routing decisions such as determining the paths that should be taken through the network. There are commonly multiple route processors in order to handle the processing load required. Of course there are additional required components such as power supplies and fans. Failure of those, such as through a power outage, will cause the router to fail. Finally, the cables connecting routers together, either electrical or optical, can also fail. Here the failure is more likely in terms of physical damage (e.g., a cut) to the cable either due to weather, construction, or vandals.

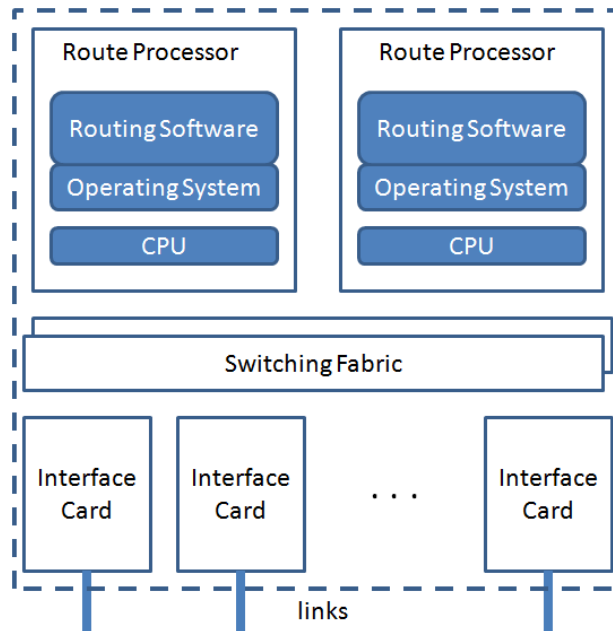

Figure 1.1: Generic diagram of a router design.

### 1.1.2 Planned Maintenance of Equipment and Software

Planned maintenance is a fact of life for network operators. Many times this comes in the form of an upgrade to the network or network components. In order to keep the network up-to-date, network operators routinely upgrade the routing software or patch the firmware in the interface cards to include the latest bug fixes and features. They may also need to add routers to keep up with growth or replace older equipment with newer versions. Planned maintenance may also come in the form of a preventative measure to address a possible problem before it arises and causes more significant disruption. If components are showing signs of failure, such as due to increased error rates, operators can replace the individual components in the modularly designed routers.

### 1.1.3 Updated Inter-domain Policy and Connectivity

Beyond failure and maintenance of the equipment, change comes from managing the operation of the network. As illustrated in Figure 1.2, the Internet is composed of a network of networks – each is known as an autonomous system (AS) and is run by a different party. Through routing protocols, these networks exchange information about the availability of paths so that the end users (clients, shown as home users, and servers, shown as data centers) spread throughout the Internet can communicate with one another. For example, AS5 will announce to its neighbors (AS1 and AS4) that they can go through AS5 to reach the block of IP addresses owned by data center A. This information will propagate throughout the network and eventually reach AS6 where it will know a path by which its customers (the home users) can reach the web service running in data center A.

By configuring the individual routers, network operators can specify policies about which paths are preferred and what information should not be told to specific neighboring networks. For example, AS4 might be a paying customer of AS2, so AS4 might

not tell AS2 that AS2 can reach data center A through AS4. Each change in policy is a change that can have Internet wide impact (or at least, impact the neighboring networks).

In managing the network, it may become necessary or highly desirable to change which internal edge router a given neighboring network connects to, or even which route processor within a router handles the routing session. This might be for load balancing purposes where one router is overloaded, so the network operator changes the router (or route processor) which handles the routing session with the neighboring network. Such changing of edge routers might alternatively be simply to support a customer request. Networks consist of a heterogeneous collection of routers, both in terms of vendor and in terms of model. As such, not all routers support the same features. If an existing customer changes some requirements, such as requesting a new quality of service feature, that is not supported on the edge router it is currently connected to, network operators must change the handling of that connection to another router.

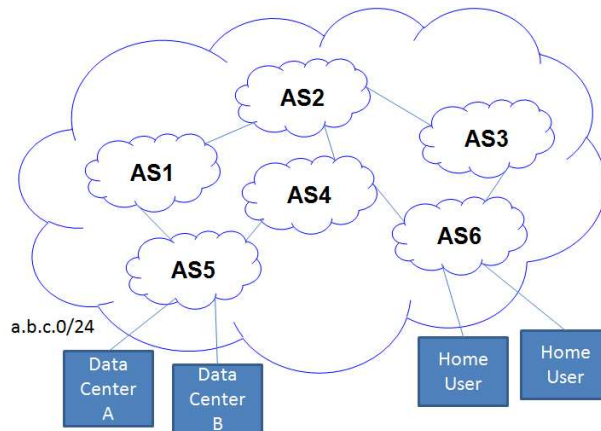

Figure 1.2: Generic network of networks consisting of end users and autonomous systems.

### 1.1.4 Changes to Optimize Resource Utilization

Network operators must also manage the resources within their own network (e.g., the available bandwidth of links, compute power of routers, and electric power of network operation centers). Similar to determining paths throughout the Internet, routing protocols are also used within one network to determine paths between ingress and egress points. For example, in the example network in Figure 1.3, to reach destination *dest1* from router *A*, a routing protocol might decide to follow the path  $A \rightarrow C \rightarrow D$ . Routing decisions can also be based on more than simply the shortest distance. Traffic engineering is the act of reconfiguring the network to optimize the flow of traffic, to minimize congestion. Today, traffic engineering involves adjusting the routing-protocol parameters to coax the routers into computing new paths that better match the offered traffic. For example, if the link between *C* and *D* is congested, a network operator might prefer to re-route some of that traffic to follow  $C \rightarrow B \rightarrow D$  instead of  $C \rightarrow D$  directly.

In addition to making traffic flow more efficiently within the network, operators can take advantage of the mostly predictable variations in traffic volumes in order to save power. It was reported that in 2000 the total power consumption of the estimated 3.26 million routers in the U.S. was about 1.1 TWh (Tera-Watt hours) [91]. This number was expected to grow to 1.9 to 2.4TWh in the year 2005 by three different projection models [91], which translates into an annual cost of about 178-225 million dollars [81]. These numbers do not include the power consumption of the required cooling systems. However, today's routers are surprisingly power-insensitive to the traffic loads they are handling—an idle router consumes over 90% of the power it requires when working at maximum capacity [31]. Instead, operators must shut off some routers during periods of lower traffic in order to save power. To make the traffic that is handled by the router that is being shut down flow through a different router,

the operator needs to configure the routers in a similar manner as is done with traffic engineering.

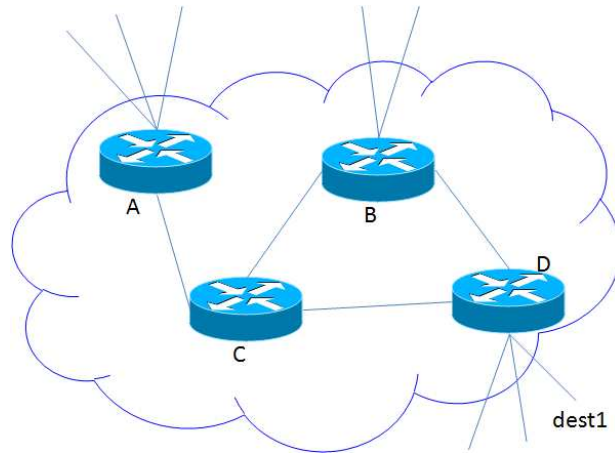

Figure 1.3: Generic network consisting of routers and links.

### 1.1.5 Service Deployment and Evolution

Deploying new services, like IPv6 or IPTV, is yet another reason for changes to networks. Here, ISPs usually start with a small trial running in a controlled environment on dedicated equipment, supporting a few early-adopter customers. This is to ensure that (i) the new services do not adversely impact existing services, and (ii) the necessary support systems are in place before services can be properly supported<sup>1</sup>. As the service moves past the initial test phase and into wider deployment, the ISP will need to restructure their test network, or move the service onto a larger network to serve a larger set of customers. This roll-out is a substantial change to the network as it effectively requires merging the configurations of the routers on one network into the routers on another network and resolving any conflicts that arise. Not only are the configurations merged, but the service is also expanded to be run on more routers, which require new configurations.

---

<sup>1</sup>Support systems include configuration management, service monitoring, provisioning, and billing.

## 1.2 Change is Painful

Whether it's a change in topology or a change in policy/preferences, whenever a change does occur, that information must get disseminated throughout the Internet. This is achieved through routing protocols, which are realized in the form of software running on each router. Here, complexity comes from (i) the distributed (in terms of many nodes working together to come to an agreement) and decentralized (in terms of authority) nature of inter-domain routing, (ii) the substantial software running on each router realizing these protocols, and (iii) the configurability of this software in order to support a wide variety of situations. Because of this complexity, change is painful.

### 1.2.1 Because Routing Software is Distributed

Focusing on a single routing protocol, the border gateway protocol (BGP) is the protocol used between networks under different administrative control (i.e., the autonomous systems) in order to exchange available routes. Each route indicates some properties about the path to the destination, such as which sequence of autonomous systems will be traversed by traffic taking that route. At its core, there are two primitive update messages: (i) announce the availability of a path to a given destination, and (ii) withdraw the availability of a path to a given destination<sup>2</sup>.

When a router receives an update, that indicates that the state of the network has changed. That router will re-run its own decision process to determine the impact on routes that it has chosen to use. If there is any change, the router will notify its neighbors. They, in turn will do the same thing. Where this causes a problem is that the changes they (or neighbors further down the line) make may affect the decisions

---

<sup>2</sup>Subsequent announcements about a previously announced prefix effectively replaces the previous announcement – only the most recent announcement for a particular destination is valid.

being made at this router. Therefore, as it is a distributed decision making process, there will be a period of time when there is disagreement within the network.

When this occurs, such issues as black holes and loops occur. A black hole is when the routes used by one network sends data traffic to another network thinking that network has a path to the destination. The black hole occurs when that network does not know a path to the destination, so it drops the traffic. Loops are where data traffic continuously traverses the same networks without reaching the destination. For example, network A thinks the path to the destination goes through Network B, but B thinks the path to the destination goes through A. So, A sends its traffic to B, who sends the traffic to A, and the traffic keeps going around.

An added complication is that it takes time to process each change. In order to not overwhelm the routers' processing capabilities, the use of timers has become commonplace. For example, the `MinRouteAdvertisementInterval` (MRAI) [85] parameter in BGP is used to limit the sending of updates to once per interval (today a value of 30sec is common). Unfortunately, this makes it take longer for the network to come to an agreement as the MRAI delays how quickly an update can make its way throughout the network.

## 1.2.2 Because Routing Software is Complex

Selecting routes involves computations across millions of routers spread over vast distances, multiple routing protocols, and highly customizable routing policies. This leads to very complex software systems.

As shown in Figure 1.4(a), these routers typically run an operating system, and a collection of protocol daemons which implement the various tasks associated with protocol operation. For example, shown are BGP, which is used for inter-domain routing (i.e., communicating with external networks), OSPF (Open Shortest Path First), which is used for intra-domain routing (determining paths within the net-

work), and a command line for configuring static routes. The BGP process needs to know the routes chosen by OSPF because the internal network distance is used in BGP’s calculation for selecting routes. For this, a route distributor will perform this distribution.

In Figure 1.4(b), the BGP routing process is shown. For each neighbor of the router, the process must maintain a session. This includes typical Unix sockets type functionality, as well as maintaining a state machine to track the various BGP states. The stream of incoming data is split up into update messages and passed to the incoming filter, which will drop or modify routes based on the router’s configuration. The update is then sent to the decision process, which performs the main functionality of the protocol – updating the RIB with the received update, reading from the the routing information base (RIB) the routes for that same prefix from the other neighbors, and deciding which of the routes is best based on the configurable preferences. The chosen route is then passed to each of the outgoing filters, one per neighbor, where based on the configuration, the filter can drop or modify the route. Finally, the update is sent to the neighboring router, possibly after some delay (e.g., based on the MRAI timer).

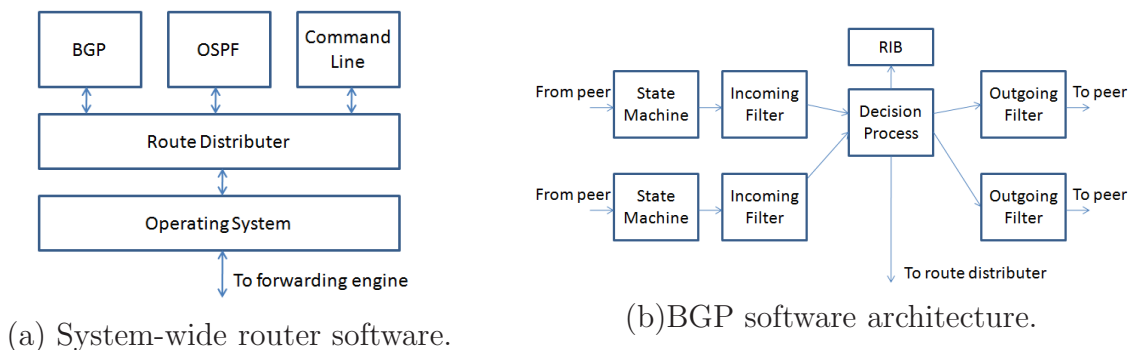

Figure 1.4: Router software architecture.

Like any complex software, routing software is prone to implementation errors, or *bugs*. Due to the critical nature of routers in today’s Internet, the effect of a bug in one of the routers can be tremendous and far reaching. This complexity has led to

several major Internet wide outages recently [87, 89, 86]. In each case, a legitimate configuration change in one network caused an update to be sent which eventually triggered a bug. This is especially damaging since there are only a limited number of router vendors and models. So, a single update can be propagated throughout the network (in all directions), and trigger the bug on a number of routers. This then causes those routers to send out bogus updates, which can either cause neighboring routers to shutdown the session (if the bogus update was malformed) or actually use and propagate the bogus route. The latter case is especially damaging since byzantine faults are harder to detect and localize than a bug which causes a crash. Luckily, a coordinated attack on the Internet routing system that exploits these bugs has not occurred yet. Though, that would be a possible way to create a ‘cyber-nuke’[88].

### 1.2.3 Because Routing Software is Configurable

Because of the effects change can have, operators must go out of their way to minimize the disruption. In fact, the cost of the people and systems that manage a network typically exceeds the cost of the underlying nodes and links [68]. Consider an example where a router needs to be replaced. In some cases, it is possible to avoid a disruption due to the router going down through a series of reconfigurations which gradually changes the routing protocol parameters to coax traffic to not go through the router in question [50][51]. Of course, the side effects of a reconfiguration, such as convergence and triggering router bugs, will still exist and can cause disruption. Further, being a human process, errors in the configurations can and do occur. Most network outages are actually caused by operator errors, rather than equipment failure [68].

Even if the operator is careful and the process can be automated, given the large and distributed nature of the Internet, an operator does not really know the full effect of a given change before it is made. A network operator might alter the configuration of a router, e.g., to change which provider is preferred, which causes a previously

unused (but known) route to now be selected. This new route might actually be a black hole that the operator did not know about. While black holes can happen as a transient behavior of the convergence process, black holes can last for hours, even days [64]. Tracking down connectivity problems is a huge effort for operators.

### 1.3 Refactoring Router Software

In order to better accommodate change in the Internet, we propose refactoring the router software. We first want to enable network operators to make changes, which if they are really just local changes, do not have any external impact. For those changes that do have an impact external to the network making the change, the changes should not cause harmful network-wide effects. Our approach is to redesign the routers rather than the routing protocols. With this, network operators can immediately gain benefits without having to coordinate with neighboring network operators or waiting for a Internet-wide upgrade to some new protocol.

As illustrated in Figure 1.5, the refactoring we are suggesting can be categorized by the various levels at which a network and the network components can be viewed and how they interact with other layers. For each boundary between layers, we provide a system that breaks the tight coupling between the layers. In doing so, the underlying infrastructure is more accommodating of change. Each is briefly introduced below, with more detail in the chapters dedicated to each system.

**Between the router software and the neighboring routers in the network (Chapter 2):** The software running on routers is large and complex, and therefore can be quite buggy. In order for the rest of the network to operate properly, we are reliant on this single piece of software to behave correctly. A buggy router can send bogus messages to the neighboring routers. We propose breaking this reliance on a single router software implementation. While providing the view of a single

router instance to the operator and neighboring routers, with the *Bug-tolerant router*, we internally restructure the software to allow multiple, diverse instances of router software to run in parallel [67]. In doing so we are able to mask errors in any single implementation. We make the case why this approach is necessary, effective, and possible. We also describe an architecture which deals with the unique properties of routing software – doing so while hiding the multiple instances and churn among the instances from both the network operator and neighboring routers. We built a prototype implementation consisting of a set of extensions built on top of Linux and tested with multiple version of XORP [9], Quagga [6], and BIRD [1]. Experiments with BGP message traces and the open-source routing software running on our Linux-based router hypervisor demonstrate that our solution scales to large networks and efficiently masks buggy behavior.

**Between the physical topology of routers and the logical IP layer topology of routers (Chapter 3):** The routing protocols work at the IP layer, essentially viewing routers as nodes in a graph and determining paths between nodes. However, this IP layer logical topology is tightly coupled to the underlying physical network. If an operator needs to, for example, shut down a physical router to perform some maintenance (e.g., replace a power supply), the corresponding node in the logical IP layer topology also must be shutdown. This then triggers the routing protocols to adapt and is the source of disruption. We propose decoupling the logical instance of a router from the physical box it runs on. This is done through *VROOM* (Virtual ROuters On the Move), a new network-management primitive that avoids unnecessary changes to the logical topology by allowing (virtual) routers to freely move from one physical node to another [103]. Revisiting the example of replacing a power supply, with VROOM the (virtual) router can be migrated to a nearby router, the power supply replaced, and the (virtual) router migrated back without ever changing the IP layer topology. We present the design of novel migration techniques for virtual routers

along with a prototype implementation consisting of extensions to an OpenVZ [5] (virtualization software) and Quagga (routing software) based system. We evaluate with both hardware (using NetFPGA [79]) and software (using Linux) data planes. Our evaluation shows that VROOM is transparent to routing protocols and results in no performance impact on the data traffic when a hardware-based data plane is used.

**Between the internal network and neighboring ASes (Chapter 4):** The connection between two networks involves the physical link between a router in each network along with a BGP session between those routers. Network operators routinely need to change which router an external network connects to (e.g., to perform maintenance, migrate load to a new router, or support a customer request). Unfortunately, the basic task of rehomeing a BGP session requires shutting down the session, reconfiguring the new router, restarting the session, and exchanging a large amount of routing information typically leading to downtimes of several minutes. This is due to the router design which binds the links and session state to a single router. We propose breaking this tight coupling. Instead, with *Router Grafting*, parts of a router are seamlessly removed from one router and merged into another [65]. We focus on grafting a BGP session and the underlying link from one router to another with no disruption. We show that grafting a BGP session is practical even with today’s monolithic router software. Our prototype implementation uses and extends Click [72], the Linux kernel, and Quagga, and introduces a daemon that automates the migration process. We also apply router grafting to intra-domain traffic engineering. Previously, intra-domain traffic engineering was limited to controlling how traffic flows through the network. With router grafting, we now have the additional capability to control where traffic enters and exits the network. We present a new optimization framework for determining what links to migrate. Our evaluation based on real traffic traces

shows that with router grafting a network can carry 18.8% more traffic (at a similar level of congestion) over optimizing routing alone.

## 1.4 Router Trends

While the proposed router software refactoring is seemingly radical, in actuality it is in line with recent trends in router and network technology. We are providing a complete system solution that capitalizes on these trends. We aim to show how the router's software could be redesigned to build a more dependable network that better accommodates change. Discussed here are some of these trends, accompanied by an illustration of each in Figure 1.6.

**Control plane, data plane split:** (Figure 1.6(a)) The control plane of the router handles the routing protocols, exchanging routing information between routers. The routes are stored in a data structure known as the routing information base (RIB). The selected routes are sent to the data plane, which stores the routes in the forwarding information base (FIB). The data plane of the router handles the actual data traffic by performing a fast lookup in the FIB to decide where to send each packet. In today's routers, there is a clear separation between the two functions – in many cases, a physical separation between the route processor and the interface cards. This separation means that there is there is a clear interface of the interaction between the control plane and the data plane, which we utilize in the bug tolerant router to perform voting on each message. Further, there is a clear separation of state – the RIB is stored in the control plane's memory space, the FIB is stored in the interface card's memory. We take advantage of this separation with VROOM as we migrate the control plane independently from the data plane.

**Virtualization on routers:** (Figure 1.6(b)) Virtualization is a technology that's popular in servers to allow a single physical server to appear like it is multiple vir-

tual servers. This enables simpler application management. Similarly, routers are becoming so large that partitioning them into smaller units would also be beneficial. As such, virtualization technology is making its way into routers [61][37]. As a first step, today’s routers utilize physical separation to provide the ability to partition the router’s physical resources (line cards, route processors) into distinct units called logical routers. Eventually, the routers will have virtualization technology on both the route processor (allowing multiple instances of router software, each with their own RIB) and on the interface cards (allowing multiple FIBs). With VROOM we utilize the live machine migration capability that is standard in modern virtual machine technology to perform the control plane migration.

**Dynamic network-layer link technology:** (Figure 1.6(c)) In order for two neighboring routers to communicate, they need a link connecting them. While this could be simply a physical cable, in today’s networks, the link connecting two routers actually goes through an underlying layer-2 network (e.g., optical switches). They have the ability to dynamically setup and tear down network-layer links, with an extremely short switchover time. We capitalize on this in both VROOM and router grafting where in order to migrate an entire virtual router or single routing session, the underlying links connecting two neighboring routers needs to be moved. If the links are physical cables which require manually unplugging from one router and then plugging into a another router, migration would be infeasible. With dynamic network-layer link setup and tear down, migration can be seamless.

**Redundancy:** (Figure 1.6(d)) Given the critical nature of the Internet, networks and routers are built with extra redundancy. The routers typically have a hot standby route processor which is synchronized with the active route processor so that the hot standby can take over for the active when the active fails [3]. Further, the network itself has additional capacity to deal with traffic spikes. As each of our systems require extra processing, with the redundancy present in the routers and network, the

necessary extra processing power is already available. With the bug tolerant router we run multiple instances, which utilizes the extra processing power in routers. With VROOM we migrate an entire virtual router, which requires a router with enough space capacity to absorb that virtual router. With Router Grafting, we migrate an individual link and associated session, which requires a spare interface and some incremental processing power.

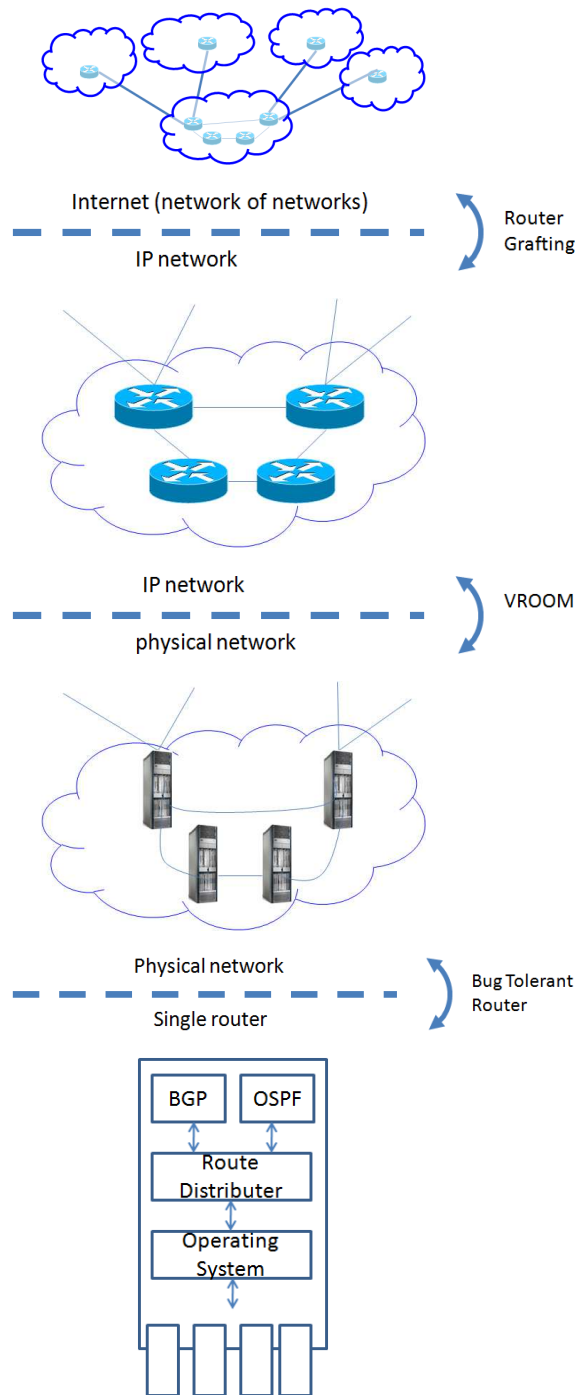
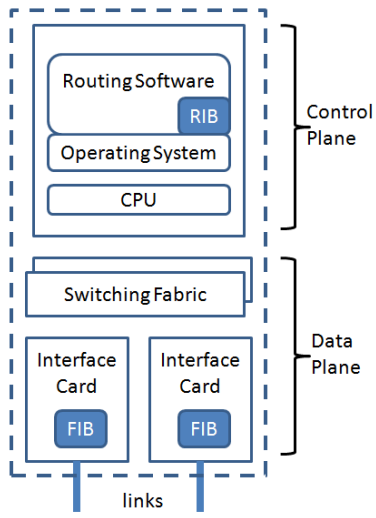
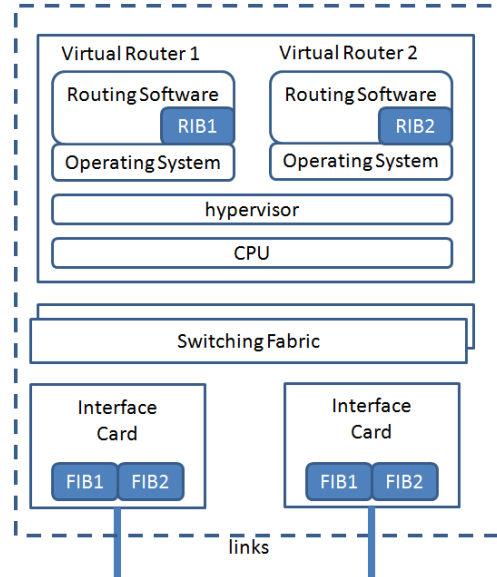

Figure 1.5: Router software refactoring.



(a) Control/Data Plane Split.



(b) Virtualization.

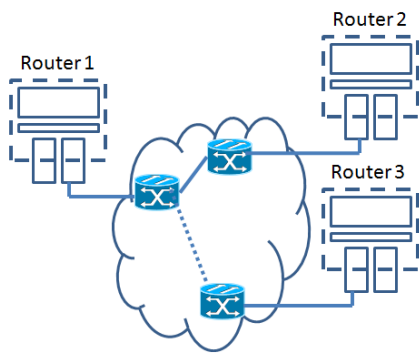

(c) Dynamic Links.

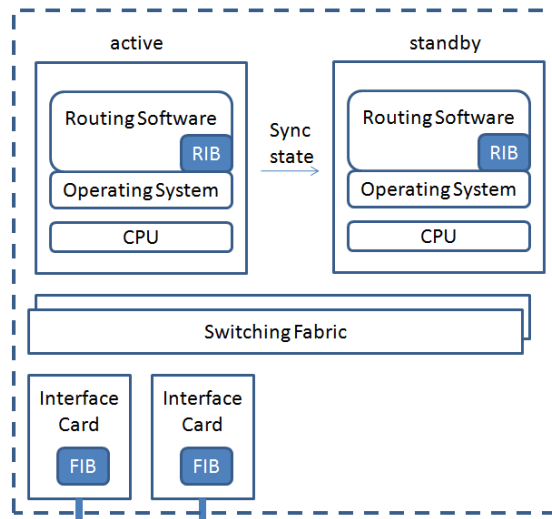

(d) Redundancy.

Figure 1.6: Router trends.

## Chapter 2

# Hiding Routing Software Bugs from Adjacent Routers with the Bug-Tolerant Router

### 2.1 Introduction

This chapter focuses on the inherent complexity of the software that is running on the routers in the Internet. These routers typically run an operating system, and a collection of protocol daemons which implement the various tasks associated with protocol operation. Like any complex software, routing software is prone to implementation errors, or *bugs*. In this chapter, we adapt diverse replication to build router software that is not only tolerant of bugs but utilizes replication in a manner that is completely transparent to neighboring routers.

#### 2.1.1 Challenges in dealing with router bugs

The fact that bugs can produce incorrect and unpredictable behavior, coupled with the mission-critical nature of Internet routers, can produce disastrous results. This

can be seen from the recent spate of high-profile vulnerabilities, outages, and huge spikes in global routing instability [87, 89, 86, 29, 45, 42, 25, 71]. Making matters worse, ISPs often run the same protocols and use equipment from the same vendor network-wide, increasing the probability that a bug causes simultaneous failures or a network-wide crash. While automated systems can *prevent* misconfigurations from occurring [46, 47], these techniques do not work for router bugs, and in fact the state-of-the-art solution today for dealing with router bugs involves heavy manual labor—testing, debugging, and fixing code. Unfortunately operators must wait for vendors to implement and release a patch for the bug, or find an intermediate work around on their own, leaving their networks vulnerable in the meantime.

Worse still, bugs are often discovered only *after* they cause serious outages. While there has been work on dealing with failures in networks [78, 75, 58], router bugs differ from traditional “fail-stop” failures (failures that cause the router to halt in some easily-detectable way) in that they violate the semantics of protocol operation. Hence a router can keep running, but behave incorrectly – by advertising incorrect information in routing updates, or by distributing the wrong forwarding-table entries to the data plane, which can trigger persistent loops, oscillations, packet loss, session failure, as well as new kinds of anomalies that can’t happen in correctly behaving protocols. This fact, coupled with the high complexity and distributed nature of Internet routing, makes router bugs notoriously difficult to detect, localize, and contain.

As networks become better at dealing with traditional failures, and as systems that automate configuration become more widely deployed, we expect bugs to become a major roadblock in improving network availability. While we acknowledge the long-standing debate in the software engineering community on whether it is possible to completely prevent software errors, we believe unforeseen interactions across protocols, the potential to misinterpret RFCs, the increasing functionality of Internet

routing, and the ossification of legacy code and protocols will make router bugs a “fact-of-life” for the foreseeable future and we proceed under that assumption.

### 2.1.2 The case for diverse replication in routers

Unlike fail-stop failures, router bugs can cause *Byzantine* faults, i.e., they cause routers to not only behave incorrectly, but violate protocol specification. Hence, we are forced to take a somewhat heavy-handed approach in dealing with them (yet as we will find, one that appears to be necessary, and one that our results indicate is practical). In particular, our design uses a simple replication-based approach: instead of running one instance of routing software, our design uses a *router hypervisor*<sup>1</sup> to run multiple *virtual* instances of routing software in parallel. The instances are made *diverse* to decrease the likelihood they all simultaneously fail due to a bug. We leverage *data diversity* (to manipulate the inputs to the router, for example by jittering arrival time of updates, or changing the layout of the executable in memory) and *software diversity* (given multiple implementations of routing protocols already exist, running several of them in parallel). We then rely on Byzantine-fault tolerant (BFT) techniques to select the “correct” route to send to the forwarding table (FIB), or advertise to a neighbor<sup>2</sup>.

The use of BFT combined with *diverse replication* (running multiple diverse instances) has proven to be a great success in the context of traditional software, for example in terms of building robust operating systems and runtime environments [33, 62, 80, 110, 20]. These techniques are widely used since heterogeneous

---

<sup>1</sup> We use the term *router hypervisor* to refer to a software layer that maintains arbitrates between outputs from multiple software replicas. However, our approach does not require true virtualization to operate, and may instead take advantage of lighter-weight containerization techniques [5].

<sup>2</sup> For BGP, sources of non-determinism such as age-based tie-breaking and non-deterministic MED must be disabled. This is often done by operators anyway because they lead to unpredictable network behavior (making it hard to engineer traffic, provision network capacity, and predict link loads).

replicas are unlikely to share the same set of bugs [33, 62, 110]. In this chapter, we adapt diverse replication to build router software that is tolerant of bugs.

A common objection of this approach is performance overheads, as running multiple replicas requires more processing capacity. However, BFT-based techniques provide a simple (and low-cost) way to leverage the increasingly parallel nature of multicore router processors to improve availability without requiring changes to router code. Network operators also commonly run separate *hardware* instances for resilience, across multiple network paths (e.g., multihoming), or multiple routers (e.g., VRRP [58]). Some vendors also protect against fail-stop failures by running a hot-standby redundant control plane either on multiple blades within a single router or even on a single processor with the use of virtual machines [35], in which case little or no additional router resources are required. Since router workloads have long periods with low load [13], redundant copies may be run during idle cycles. Recent breakthroughs vastly reduce computational overhead [111] and memory usage [56], by skipping redundancy across instances.

### 2.1.3 Designing a Bug-Tolerant Router

In this chapter, we describe how to eliminate router bugs “virtually” (with use of virtualization technologies). We design a *bug-tolerant* router (BTR), which masks buggy behavior, and avoids letting it affect correctness of the network layer, by applying software and data diversity to routing. Doing so, however, presents new challenges that are not present in traditional software. For example, (i) wide-area routing protocols undergo a rich array of dynamics, and hence we develop BFT-based techniques that react quickly to buggy behavior without over-reacting to transient inconsistencies arising from routing convergence, and (ii) our design must interoperate with existing routers, and not require extra configuration efforts from operators, and hence we

develop a *router hypervisor* that masks parallelism and churn (*e.g.*, killing a faulty instance and bootstrapping a new instance).

At the same time we leverage new opportunities made available by the nature of routing to build custom solutions and extend techniques previously developed for traditional software. For example, (i) routers are typically built in a modular fashion with well-defined interfaces, allowing us to adapt BFT with relatively low complexity, and implement it in the hypervisor with just a few hundred lines of code, (ii) using mechanisms that change transient behavior without changing steady-state outcomes are acceptable in routing, which we leverage to achieve diversity across instances, and (iii) routing has limited dependence on past history, as the effects of a bad FIB update or BGP message can be undone simply by overwriting the FIB or announcing a new route, which we leverage to speed reaction by selecting a route early, when only a subset of instances have responded, and updating the route as more instances finish computing. Moreover, router outputs are independent of the precise ordering and timing of updates, which simplifies recovery and bootstrapping new instances.

The next section discusses how diversity can be achieved and how effective it is, followed by a description of our design (Section 2.3) and implementation (Section 2.4). We then give performance results in Section 2.5, consider possible deployment scenarios in Section 2.6, contrast with related work in Section 2.7, and conclude in Section 2.8.

## 2.2 Software and Data Diversity in Routers

The ability to achieve diverse instances is essential for our bug-tolerant router architecture. Additionally, for performance reasons, it is important that the number of instances that need to be run concurrently is minimal. Fortunately, the nature of routing and the current state of routing software lead to a situation where we are able

to achieve enough diversity and that it is effective enough that only a small number of instances are needed (*e.g.*, 3-5, as discussed below). In this section we discuss the various types of diversity mechanisms, in what deployment scenario they are likely to be used, and how effective they can be in avoiding bugs.

Unfortunately, directly evaluating the benefits of diversity across large numbers of bugs is extremely challenging, as it requires substantial manual labor to reproduce bugs. Hence, to gain some rough insights, we studied the bug reports from the XORP and Quagga Bugzilla databases [9, 6], and taxonomized each into what type of diversity would likely avoid the bug and experimented with a small subset, some of which are described in Table 2.1.<sup>3</sup>

### 2.2.1 Diversity in the software environment

**Code base diversity** : The most effective, and commonly thought of, type of diversity is where the routing software comes from different code bases. While often dismissed as being impractical because a company would never deploy multiple teams to develop the same software, we argue that diverse software bases are already available and that router vendors do not need to start from scratch and deploy multiple teams.

First, consider that there are already several open-source router software packages available (*e.g.*, XORP, Quagga, BIRD). Their availability has spawned the formation of a new type of router vendor based on building a router around open-source software [8, 9].

Additionally, the traditional (closed-source) vendors can make use of open-source software, something they have done in the past (*e.g.*, Cisco IOS is based on BSD Unix), and hence may run existing open-source software as a “fallback” in case their

---

<sup>3</sup>To compare with closed-source software, we also studied publicly available Cisco IOS bug reports, though since we do not have access to IOS source code we did not run our system on them.

<b>Bug</b>	<b>Description</b>	<b>Effective Diversity</b>
XORP 814	The asynchronous event handler did not fairly allocate its resources when processing events from the various file descriptors. Because of this, a single peer sending a long burst of updates could cause other sessions to time out due to missed keepalives.	Version (worked in 1.5, but not 1.6)
Quagga 370	The BGP default-originate command in the configuration file does not work properly, preventing some policies from being correctly realized.	Version (worked in 0.99.5, but not 0.99.7)
XORP 814	(See above)	Update (randomly delay delivery)
Quagga (not filed)	A race condition exists such that when a prefix that is withdrawn and immediately re-advertised, the router only propagates to peers the withdraw message, and not the subsequent advertisement. Note: it was reported on the mailing list titled “quick route flap gets mistaken for duplicate, route is then ignored,” but never filed in Bugzilla.	Update (randomly delay delivery)
XORP 31	A peer that initiates a TCP connection and then immediately disconnects causes the BGP process to stop listening for incoming connections.	Connection (can delay disconnect)
Quagga 418	Static routes that have an unreachable next hop are correctly considered inactive. However, the route remains inactive even when the address of network device is changed to something that would make the next hop reachable (e.g., a next hop of 10.0.0.1 and an device address that changed from 9.0.0.2/24 to 10.0.0.2/24)	Connection (can interpret change as reset as well).

Table 2.1: Example bugs and the diversity that can be used to avoid them.

main routing code crashes or begins behaving improperly. Router vendors that do not wish to use open-source software have other alternatives for code diversity, for example, router vendors commonly maintain code acquired from the purchase of other companies [84].

As a final possibility, consider that ISPs often deploy routers from multiple vendors. While it is possible to run our bug-tolerant router across physical instances, it is most practical to run in a single, virtualized, device. Even without access to the source code, this is still a possibility with the use of publicly available router emulators [2, 4]. This way, network operators can run commercial code along with our hypervisor directly on routers or server infrastructure without direct support from vendors. While intellectual property restrictions arising from their intense competition makes vendors reticent to share source code with one another, this also makes it likely that different code bases from different vendors are unlikely to share code (and hence unlikely to share bugs).

We base our claim that this is the most effective approach partially from previous results which found that software implementations written by different programmers are unlikely to share the vast majority of implementation errors in code [70]. This result can be clearly seen in two popular open-source router software packages: Quagga and XORP differ in terms of update processing (timer-driven vs. event-driven), programming language (C vs. C++), and configuration language, leading to different sorts of bugs, which are triggered on differing inputs. As such, code-base diversity is very effective and requires only three instances to be run concurrently.

However, effectively evaluating this is challenging, as bug reports typically do not contain information about whether inputs triggering the bug would cause other code bases to fail. Hence we only performed a simple sanity-check: we selected 9 bugs from the XORP Bugzilla database, determined the router inputs which triggered the bug, verified that the bug occurred in the appropriate branch of XORP code, and then

replayed the same inputs to Quagga to see if it would simultaneously fail. We then repeated this process to see if Quagga’s bugs existed in XORP. In this small check, we did not find any cases where a bug in one code base existed in the other, mirroring the previous findings.

**Version diversity** : Another source of diversity lies in the different versions of the same router software itself. One main reason for releasing a new version of software is to fix bugs. Unfortunately, operators are hesitant to upgrade to the latest version until it has been well tested, as it is unknown whether their particular configuration, which has worked so far (possibly by chance), will work in the latest version. This hesitation comes with good reason, as often times when fixing bugs or adding features, new bugs are introduced into code that was previously working (i.e., not just in new features). This can be seen in some of the example bugs described in Table 2.1. With our bug-tolerant router, we can capitalize on this diversity.

For router vendors that fully rely on open-source software, version diversity will add little over the effectiveness of code-base diversity (assuming they use routers from three code bases). Instead, version diversity makes the most sense for router vendors that do not fully utilize code-base diversity. In this case, running the old version in parallel is protection against any newly introduced bugs, while still being able to take advantage of the bug fixes that were applied.

Evaluating this is also a challenge as bug reports rarely contain the necessary information. Because of this, to evaluate the fraction of bugs shared across versions (and thus, the effectiveness), we ran static analysis tools (splint, uno, and its4) over several versions of Quagga, and investigated overlap across versions. For each tool, we ran it against each of the earlier versions, and then manually checked to see how many bugs appear in both the earlier version as well as the most recent version. We found that overlap decreases quickly, with 30% of newly-introduced bugs in 0.99.9 avoided by using 0.99.1, and only 25% of bugs shared across the two versions. As it

is not 100% effective, this will most likely be used in combination with other forms of diversity (*e.g.*, diversity in the execution environment, described next).

### 2.2.2 Execution environment diversity

Data diversity through manipulation of the execution environment has been shown to automatically recover from a wide variety of faults [20]. In addition, routing software specific techniques exist, two of which are discussed below. As closed-source vendors do not get the full benefit from running from multiple code bases, they will need to rely on data diversity, most likely as a complement to version diversity. In that case, around five instances will be needed depending on the amount of difference between the different versions. This comes from the result of our study which showed version diversity to be 75% effective, so we assume that two versions will be run, each with two or three instances of that version (each diversified in terms of execution environment, which as we discuss below can be fairly effective).

**Update timing diversity:** Router code is heavily concurrent, with multiple threads of execution and multiple processes on a single router, as well as multiple routers simultaneously running, and hence it is not surprising that this creates the potential for concurrency problems. Luckily, we can take advantage of the asynchronous nature of the routing system to increase diversity, for example, by introducing delays to alter the timing/ordering of routing updates received at different instances without affecting the correctness of the router (preserving any ordering required by the dependencies created by the protocol, *e.g.*, announcements for the same prefix from a given peer router must be kept in order, but announcements from different peer routers can be processed in any order). We were able to avoid two of the example bugs described in Table 2.1 with a simple tool to introduce a randomized short delay (1-10ms) when delivering messages to the given instance. Further, by manually

examining the bug databases, we found that approximately 39% of bugs could be avoided by manipulating the timing/ordering of routing updates.

**Connection diversity:** Many bugs are triggered by changes to the router’s network interfaces and routing sessions with neighbors. From this, we can see that another source of diversity involves manipulating the timing/order of events that occur from changes in the state or properties of the links/interfaces or routing session. As our architecture (discussed in Section 2.3) introduces a layer between the router software and the sessions to the peer routers, we can modify the timing and ordering of connection arrivals or status changes in network interfaces. For the two example bugs in Table 2.1, we found they could be avoided by simple forms of connection diversity, by randomly delaying and restarting connections for certain instances. By manually examining the bug database, we found that approximately 12% of bugs could be avoided with this type of diversity.

### 2.2.3 Protocol diversity

As network operators have the power to perform configuration modifications, something the router vendors have limited ability to do, there are additional forms of diversity that they can make use of. Here, we discuss one in particular. The process of routing can be accomplished by a variety of different techniques, leading to multiple different routing *protocols* and algorithms, including IS-IS, OSPF, RIP, etc. While these implementations differ in terms of the precise mechanisms they use to compute routes, they all perform a functionally-equivalent procedure of determining a FIB that can be used to forward packets along a shortest path to a destination. Hence router vendors may run multiple different routing protocols in parallel, voting on their outputs as they reach the FIB. To get some rough sense of this approach, we manually checked bugs in the Quagga and XORP Bugzilla databases to determine the fraction that resided in code that was shared between protocols (e.g., the

*zebra* daemon in Quagga), or code that was protocol independent. From our analysis, we estimate that at least 60% of bugs could be avoided by switching to a different protocol.

## 2.3 Bug Tolerant Router (BTR)

Our design works by running multiple diverse router instances in parallel. To do this, we need some way of allowing multiple router software instances to simultaneously execute on the same router hardware. This problem has been widely studied in the context of operating systems, through the use of *virtual machine* (VM) technologies, which provide isolation and arbitrate sharing of the underlying physical machine resources. However, our design must deal with two new key challenges: (i) replication should be transparent and hidden from network operators and neighboring routers (Section 2.3.1), and (ii) reaching consensus must handle the transient behavior of routing protocols, yet must happen quickly enough to avoid slowing reaction to failures (Section 2.3.2).

### 2.3.1 Making replication transparent

First, our design should hide replication from neighboring routers. This is necessary to ensure deployability (to maintain sessions with legacy routers), efficiency (to avoid requiring multiple sessions and streams of updates between peers), and ease of maintenance (to avoid the need for operators to perform additional configuration work). To achieve this, our design consists of a *router hypervisor*, as shown in Figure 2.1. The router hypervisor performs four key functions:

**Sharing network state amongst replicas:** Traditional routing software receives routing updates from neighbors, and uses information contained within those updates to select and compute paths to destinations. In our design, multiple instances of router

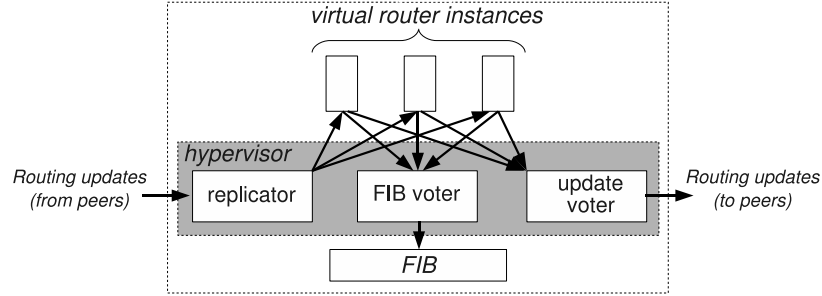

Figure 2.1: Architecture of a bug-tolerant router.

software run in parallel, and somehow all these multiple router instances need to learn about routes advertised by neighbors. To compute routes, each internal instance needs to be aware of routing information received on peering sessions. However, this must happen without having instances directly maintain sessions with neighboring routers. To achieve this, we use a *replicator* component, which acts as a replica coordinator to send a copy of all received data on the session to each router instance within the system. Note that there may be multiple sessions with a given peer router (*e.g.*, in the case of protocol diversity), in which case the replicator sends received data to the appropriate subset of instances (*e.g.*, those running the same protocol). The replicator does *not* need to parse update messages, as it simply forwards all data it receives at the transport layer to each instance.

**Advertising a single route per prefix:** To protect against buggy results, which may allow the router to keep running but may cause it to output an incorrect route, we should select the majority result when deciding what information to publish to the FIB, or to advertise to neighbors. To do this, we run a *voter* module that monitors advertisements from the router instances, and determines the route the router should use (*e.g.*, the majority result).<sup>4</sup> Our design contains two instances of the voter: an *update voter* that determines which routing updates should be sent to neighbors, and a *FIB voter* that determines which updates should be sent to the router’s FIB

<sup>4</sup>Since voting also reveals the set of misbehaving instances, our approach also simplifies diagnosis, as the hypervisor can explicitly report the set of buggy outputs it observes.

(forwarding table). As with the replicator, the update voter may vote among a subset of instances, for example, those belonging to the same protocol. The FIB voter will vote among all instances, as all instances must come to the same decisions with regard to the FIB. To ensure advertisements are consistent with FIB contents, the update voter and FIB voter must select the same routes. To handle this, the same voting algorithm must be used on both updates and FIB changes.

To avoid introducing bugs, the voter should be as simple as possible (our voter implementation, containing multiple alternative voting strategies, is 514 lines of code). We assume the voter is trusted (since it is much simpler than router code, we expect it to have significantly fewer bugs and therefore the fact that it is a single point-of-failure is only a slight concern), and that replication is asynchronous (we do not assume all instances respond equally fast, as instances may be slow or mute due to bugs), and transparent (external routers do not interact directly with the multiple instances, so as to simplify deployment).

**Maintaining a set of running replicas:** BFT-based techniques rely on having a sufficient number of correctly-behaving replicas in order to achieve consensus. Hence, if an instance crashes or begins producing buggy output, we may wish to replace it with a new copy. To achieve this, our hypervisor is responsible for *bootstrapping* the new instance when it begins running. For traditional routers, bootstrapping involves establishing a session with a neighboring router, which causes the neighboring router to send out update messages for each of the prefixes it has an entry for in its RIB. To avoid introducing externally visible churn, the hypervisor keeps a history of the last update peers have sent for each prefix, and replays this for any new instance upon startup of that instance.

**Presenting a common configuration interface:** As there is no standardization of the configuration interface in routers, each router has ended up with its own interface. In the case where instances from different code bases are used, to keep the

network operator from needing to configure each instance separately, a mechanism is needed to hide the differences in each configuration interface. Fortunately, this is not unlike today’s situation where ISPs use routers from multiple vendors. To cope with this, ISPs often run configuration management tools which automate the process of targeting each interface with a common one. As such, we can rely on these same techniques to hide the configuration differences.

### 2.3.2 Dealing with the transient and real-time nature of routers

The voter’s job is to arbitrate amongst the “outputs” (modifications to the FIB, outbound updates sent to neighbors) of individual router instances. This is more complex than simply selecting the majority result – during convergence, the different instances may temporarily have different outputs without violating correctness. At the same time, routers must react quickly enough to avoid slowing convergence. Here, we investigate several alternative voting strategies to address this problem, along with their tradeoffs.

**Handling transience with *wait-for-consensus*:** The extreme size of the Internet, coupled with the fact that routing events are propagated globally and individual events trigger multiple routing updates, results in very high update rates at routers. With the use of replication, this problem is potentially worsened, as different instances may respond at different times, and during convergence they may temporarily (and legitimately) produce different outputs. To deal with this, we use *wait-for-consensus* voting, in which the voter waits for all instances to compute their results before determining the majority vote. Because all non-buggy routers output the same correct result in steady-state, this approach can guarantee that if  $k$  or fewer instances are faulty with at least  $2k + 1$  instances running, no buggy result will reach the FIB or be propagated to a peer.

Note that in practice, waiting for consensus may also reduce instability, as it has an effect similar to the MRAI (Minimum Route Advertisement Interval) timer (routers with MRAI send updates to their neighbors only when a timer expires, which eliminates multiple updates to a prefix that occur between timer expiries). Namely, forcing the voter to wait for all instances to agree eliminates the need to advertise changes that happen multiple times while it is waiting (e.g., in the presence of unstable prefixes). However, the downside of this is that reaction to events may be slowed in some cases, as the voter must wait for the  $k + 1$ th slowest instance to finish computing the result before making a decision.

**Speeding reaction time with *master/slave*:** Routers must react quickly to failures (including non-buggy events) to ensure fast convergence and avoid outages. At the same time, the effects of a bad FIB update or BGP message can be undone simply by overwriting the FIB or announcing a new route. To speed reaction time, we hence consider an approach where we allow outputs to temporarily be faulty. Here, we mark one instance as the *master*, and the other instances as slaves. The voter operates by always outputting the master's result. The slaves' results are used to cross-check against the master after the update is sent or during idle cycles. The benefit of this approach is that it speeds convergence to the running time of the master's computation. In addition, convergence is no worse than the convergence of the master, and hence at most one routing update is sent for each received update. However, the downside of this approach is that if the master becomes buggy, we may temporarily output an incorrect route. To address this, when failing over to a slave, the voter readvertises any differences between the slaves' routing tables and the routing table computed by the master. Hence, temporarily outputting an incorrect route may not be a problem, as it only leads to a transient problem that is fixed when the slaves overthrow the master.

Finally, we consider a hybrid scheme which we refer to as *continuous-majority*. This approach is similar to wait-for-consensus in that the majority result is selected to be used for advertisement or for population into the FIB. However, it is also similar to master/slave in that it does not wait for all instances to compute results before selecting the result. Instead, every time an instance sends an update, the voter reruns its voting procedure, and updates are only sent when the majority result changes. The benefit of this approach is it may speed reaction to failure, and the majority result may be reached before the slowest instance finishes computing. The downside of this approach is that convergence may be worsened, as the majority result may change several times for a single advertised update. Another downside of this approach is that voting needs to be performed more often, though, as we show in our experiments (Section 2.5) this overhead is negligible under typical workloads.

## 2.4 Router Hypervisor Prototype

Our implementation had three key design goals: (i) not requiring modifications to routing software, (ii) being able to automatically detect and recover from faults, and (iii) low complexity, to not be a source of new bugs. Most of our design is agnostic to the particular routing protocol being used. For locations where protocol-specific logic was needed, we were able to treat messages mostly as opaque strings. This section describes our implementation, which consists of a set of extensions built on top of Linux. Our implementation was tested with XORP versions 1.5 and 1.6, Quagga versions 0.98.6 and 0.99.10, and BIRD version 1.0.14. We focused our efforts on supporting BGP, due to its complexity and propensity for bugs. Section 2.4.1 describes how we provide a *wrapper* around the routing software, in order for unmodified routing software to be used, and Section 2.4.2 describes the various faults that can occur and how our prototype detects and recovers from them.

### 2.4.1 Wrapping the routing software

To eliminate the need to modify existing router software, our hypervisor acts as a wrapper to hide from the routing software the fact that it is a part of a bug-tolerant router, and allows the routing instances to share resources such as ports, and access to the FIB. Our design (Figure 2.2) takes advantage of the fact that sockets are used for communicating with peer routers, and for communicating forwarding table (FIB) updates to the kernel. Hence, our implementation intercepts socket calls from the router instances using the `LD_PRELOAD` environment variable and uses a modified libc library, called *hv-libc*, to redirect messages to a user-space module, called *virt*, which manages all communication.

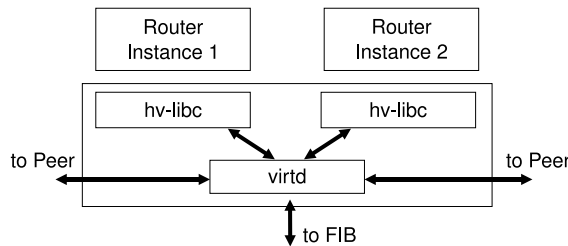

Figure 2.2: Implementation architecture.

The two key functions the hypervisor then needs to manage are discussed below:

**Socket-based communications:** To connect to peer routers (with TCP) and for writing to the common FIB (with Netlink), the multiple routers need to share access to a common identifier space (*e.g.*, port 179 in BGP). We handle this by intercepting socket system calls in *hv-libc*, performing address translation in *hv-libc*, and using *virt* as a proxy (*e.g.*, when a router instance listens on port 179, instead they are made to listen on a random port and *virt* will listen on 179 and connect to each of the random ports when receiving an incoming connection).

**Bootstrapping new connections:** When the BTR initially starts up, the routing instances start with empty routing tables. In BGP, a session with a peer is established by creating a TCP connection, exchanging OPEN messages, and acknowledging the

OPEN message with a KEEPALIVE message. After the session is established, the peers exchange routing information. However, when replacing a failed instance, we need to bootstrap it locally, to prevent the failure from being externally visible (*e.g.*, sending a *route-refresh* to a peer). Additionally, we need to bootstrap it independently, to prevent the new instance starting in a faulty state (*e.g.*, bootstrapping off another router instance). Since a router's state only depends on the last received RIB advertised by its neighbors, we add some additional logic to the hypervisor to store the last-received update for each (prefix,neighbor) pair. Then when a new instance is started, the hypervisor replays its stored updates. To lower complexity, the hypervisor treats the (prefix, neighbor) fields and other attributes in the packets as opaque strings, and does not implement protocol logic such as route selection.

## 2.4.2 Detecting and recovering from faults

To deal with bugs, our hypervisor must *detect* which outputs are buggy (*e.g.*, with voting), and *recover* from the buggy output (by advertising the voting result, and if necessary restarting/replacing the buggy instance).

**Detection:** One of our main goals is that the BTR should be able to automatically detect and recover from bugs affecting correctness of the router's control or data planes.<sup>5</sup> Since our design fundamentally relies on detecting differences in *outputs* of different instances, we need to handle every possible way their outputs could differ. All faults can be generalized to four categories: (i) an instance sending a message when it should not, (ii) an instance not sending a message when it should, (iii) an instance sending a message with incorrect contents, and (iv) bugs that cause a detectable faulty system event, such as process crashing or socket error. The first three categories are detected by using voting (the fourth category is easily detectable, so no further discussion is given). If an instance has a different output from the

---

<sup>5</sup>We do not address, for example, faults in logging.

majority, we consider it a fault. For example, in case (i) above, the winning update will be the NULL update, in cases (ii) and (iii) the winning update will be the most-commonly advertised one. To avoid reacting to transient changes, voting is only performed across *steady-state* instance outputs, which have been stable for a threshold period of time. We then mark instances whose steady-state outputs differ from those of the majority or those that are not yet stable as being faulty (including in schemes like master/slave, which perform this step after advertising).<sup>6</sup>

**Recovery:** In the common case, recovering from a buggy router simply involves using the output from the voting procedure. However, to deal with cases where the router is persistently buggy, or crashes, we need some way to kill and restart the router. As a heuristic, we modified our hypervisor with a *fault threshold* timeout. If an instance continues to produce buggy output for longer than the threshold, or if the router undergoes a faulty system event, the router is killed. To maintain a quorum of instances on which voting can be performed, the BTR can restart the failed instance, or replace it with an alternate diverse copy. In addition, to support the master/slave voting scheme, we need some way to overwrite previously-advertised buggy updates. To deal with this, our implementation maintains a history of previously-advertised updates when running this voting scheme. When the hypervisor switches to a new master, all updates in that history that differ from the currently advertised routes are sent out immediately.

### 2.4.3 Reducing complexity

It is worth discussing here the role the hypervisor plays in the overall reliability of the system. As we are adding software, this can increase the possibility of bugs in the overall system. In particular, our goals for the design are that (i) the design is

---

<sup>6</sup>We consider legitimate route-flapping due to persistent failures and protocol oscillations to be rare. However, we can detect this is occurring as the majority of instances will not be stable and we can act accordingly.

*simple*, implementing only a minimal set of functionality, reducing the set of components that may contain bugs, and (ii) the design is *small*, opening the possibility of formal verification of the hypervisor – a more realistic task than verifying an entire routing software implementation. To achieve these goals, our design only requires the hypervisor to perform two functions: (i) acting as a TCP proxy, and (ii) bootstrapping new instances. Below, we described how these functions are performed with low complexity.

*Acting as a TCP proxy:* To act as a TCP proxy simply involves accepting connections from one end point (remote or local) and connecting to the other. When there is a TCP connection already, the hypervisor simply needs to accept the connection. Then, upon any exchange of messages (in or out) the hypervisor simply passes data from one port to another. In addition, our design uses voting to make replication transparent to neighboring routers. Here, the update messages are voted upon before being sent to the adjacent router. However, this is simply comparing opaque strings (the attributes) and does not involve understanding the values in the strings.

Overall, our implementation included multiple algorithms and still was only 514 lines of code. These code changes occur only in the hypervisor, reducing potential for new bugs by increasing modularity and reducing need to understand and work with existing router code. From this, we can see that the hypervisor design is simple in terms of functionality and much of the functionality is not in the critical section of code that will act as a single point of failure.

*Bootstrapping new instances:* To bootstrap new instances requires maintaining some additional state. However, bugs in this part of the code only affect the ability to bootstrap new instances, and do not affect the “critical path” of voting code. One can think of this code as a parallel routing instance which is used to initialize the state of a new instance. Of course, if this instance’s RIB is faulty, the new instance will be started in an incorrect state. However, this faulty state would either be automatically

corrected (*e.g.*, if the adjacent router sends a new route update that overwrites the local faulty copy) or it would be determined to be faulty (*e.g.*, when the faulty route is advertised), in which case a new instance is started. Additionally, the RIB that needs to be kept is simply a history of messages received from the adjacent router and therefore is simple. Bootstrapping a new instance also requires intercepting BGP session establishment. Here, the hypervisor simply needs to observe the first instance starting a session (an OPEN message followed by a KEEPALIVE) and subsequent instances simply get the two received messages replayed.

## 2.5 Evaluation

We evaluate the three key assumptions in our work:

*It is possible to perform voting in the presence of dynamic churn (Section 2.5.1):*

Voting is simple to do on fixed inputs, but Internet routes are transient by nature. To distinguish between instances that are still converging to the correct output from those that are sending buggy outputs, our system delays voting until routes become stable, introducing a tradeoff between false positives (incorrectly believing an unstable route is buggy) and detection time (during which time a buggy route may be used). Since these factors are independent of the precise nature of bugs but depend on update dynamics, we inject synthetic faults, and replay real BGP routing traces.

*It is possible for routers to handle the additional overhead of running multiple instances (Section 2.5.2):*

Internet routers face stringent performance requirements, and hence our design must have low processing overhead. We evaluate this by measuring the *pass-through time* for routing updates to reach the FIB or neighboring routers after traversing our system. To characterize performance under different operating conditions, we vary the routing update playback rate, the source of updates (edge vs. tier-1 ISP), and the number of peers.

*Running multiple router replicas does not substantially worsen convergence (Section 2.5.3):* Routing dynamics are highly dependent on the particular sequence of steps taken to arrive at the correct route – choosing the wrong sequence can vastly increase processing time and control overhead. To ensure our design does not harm convergence, we simulate update propagation in a network of BTRs, and measure convergence time and overhead. For completeness, we also cross-validate these against our implementation.

### 2.5.1 Voting in the presence of churn

To evaluate the ability to perform voting in the presence of routing churn, we replayed BGP routing updates collected from Route Views [7] against our implementation. In particular, we configure a BGP trace replayer to play back a 100 hour long trace starting on March 1st 2007 at 12:02am UTC. The replayer plays back multiple streams of updates, each from a single vantage point, and we collect information on the amount of time it takes the system to select a route. Since performance is dependent only on whether the bug is detected by voting or not, and independent of the particular characteristics of the bug being injected, here we use a simplified model of bugs (based on the model presented in Section 2.4.2), where bugs add/remove updates and change the next-hop attribute for a randomly-selected prefix, and have two parameters: (i) *duration*, or the length of time an instance’s output for a particular prefix is buggy, (ii) *interarrival time*, or the length of time between buggy outputs. As a starting point for our baseline experiments, we assume the length of time a bug affects a router, and their interarrival times, are similar to traditional failures, with duration of 600 seconds, and interarrival time of 1.2 million seconds [76].

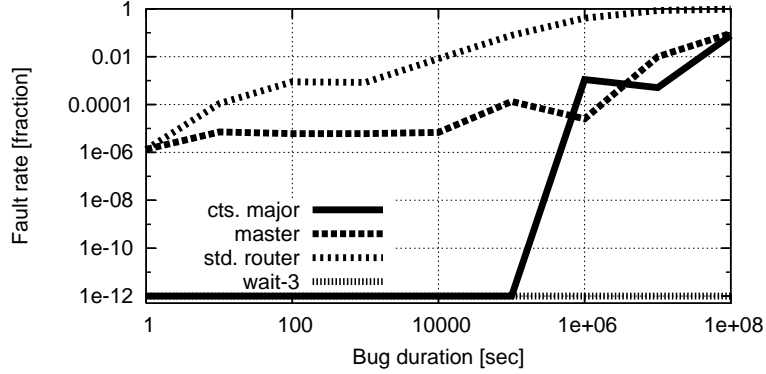

Figure 2.3: Effect of bug duration on fault rate, holding bug interarrival times fixed at 1.2 million seconds.

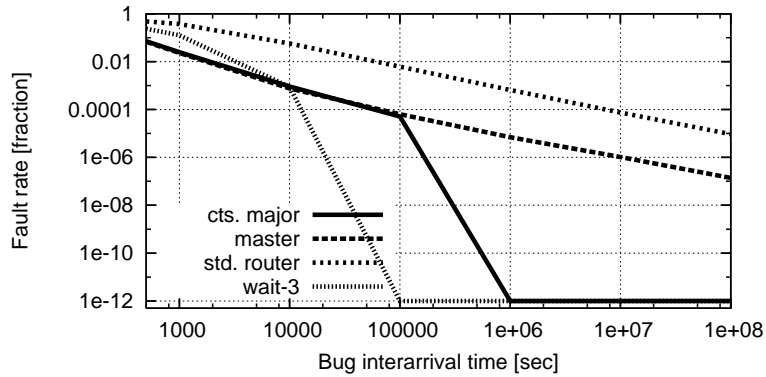

Figure 2.4: Effect of bug interval on fault rate, holding bug duration fixed at 600 seconds.

## Comparison of voting strategies

There is a very wide space of voting strategies that could be used in our system. To explore tradeoffs in this space, we investigated performance under a variety of alternative voting strategies and parameter settings. We focus on several metrics: the *fault rate* (the fraction of time the voter output a buggy route), *waiting time* (the amount of time the voter waits before outputting the correct route) and *update overhead* (the number of updates the voter output).

**Fault rate:** We investigate the fault rate of the voting strategies by injecting synthetic faults and varying their properties. First, we varied the mean duration and interarrival times of synthetic faults (Figures 2.3 and 2.4). We found that for very high bug rates, wait-3 (waiting for  $K = 3$  out of  $R = 3$  copies to agree before

selecting the majority result) outperformed master/slave. This happened because wait-3 is more robust to simultaneous bugs than master/slave, as master/slave takes some short time to detect the fault, potentially outputting an incorrect route in the meantime. In addition, unless the bug rate is extremely high, continuous-majority performs nearly as well as wait-3, with similar robustness and update overhead.

Overall, we found that recovery almost always took place within one second. Increasing the number of instances running in parallel ( $R$ ) makes the router even more tolerant of faults, but incurs additional overheads. Also, wait-for-consensus and continuous-majority gain more from larger values of  $R$  than the master/slave strategy. For example, when moving from  $R = 3$  to  $R = 4$  instances, the fault rate decreases from 0.088% to 0.003% with wait-for-consensus, while with master/slave the fault rate only decreases from 0.089% to 0.06%.

However, there may be practical limits on the amount of diversity achievable (for example, if there is a limited number of diverse code instances, or a bound on the ability to randomize update timings). This leads to the question—if we have a fixed number of diverse instances, how many should be run, and how many should be kept as standbys (not running, but started up on demand)? We found that standby routers were less effective than increasing  $R$ , but only for small values of  $R$ , indicating that for large numbers of diverse instances, most instances could be set aside as standbys to decrease runtime overhead. For example, if  $R = 3$ , under the continuous-majority strategy we attain a fault rate of 0.02%. Increasing  $R$  to 4 reduced the fault rate to 0.0006%, while instead using a standby router with  $R = 3$  reduced the fault rate to 0.0008%. This happens because buggy outputs are detected quickly enough that failing over to a standby is nearly as effective as having it participate in voting at every time step. Because of this, operators can achieve much of the benefits of a larger number of instances, even if these additional instances are run as lower-priority (e.g., only updated during idle periods) standbys.

**Waiting time:** Different voting algorithms provide different tradeoffs between waiting time (time from when a new best-route arrives, to when it is output by the voter) and the fault rate. The master/slave strategy provides the smallest waiting time (0.02 sec on average), but incurs a higher fault rate (0.0006% on average), as incorrect routes are advertised for a short period whenever the master becomes buggy. Continuous-majority has longer wait times (0.035 sec on average), but lower fault rate (less than 0.00001% on average), as routes are not output until multiple instances converge to the same result. The wait-for-consensus strategy’s performance is a function of the parameter  $K$ —larger values of  $K$  increase wait time but decreases fault rate. However, we found that increasing  $K$  to moderate sizes incurred less delay than the pass-through time for a single instance, and hence setting  $K = R$  offered a low fault rate with only minor increases in waiting time.

**Update overhead:** Finally, we compare the voting strategies in terms of their effect on update overhead (number of routing updates they generate), and compare them against a standard router (*std. router*). Intuitively, running multiple voters within a router might seem to increase update overhead, as the voter may change its result multiple times for a single routing update. However, in practice, we find no substantial increase, as shown in Figure 2.5, which plots a CDF of the number of updates (measured over one second intervals). For the master/slave strategy this is expected, since a single master almost always drives computation. In wait-for-consensus, no updates are generated until all instances arrive at an answer, and hence no more than one outbound update is generated per inbound update, as in a standard router. Interestingly, the continuous-majority strategy also does not significantly increase update overhead. This happens because when an update enters the system, the voter’s output will only change when the majority result changes, which can only happen once per update.

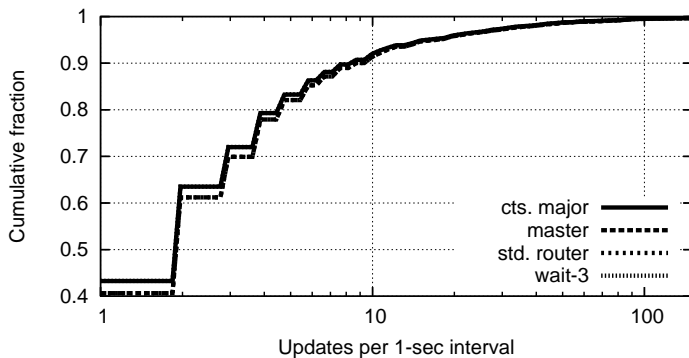

Figure 2.5: Effect of voting on update overhead.

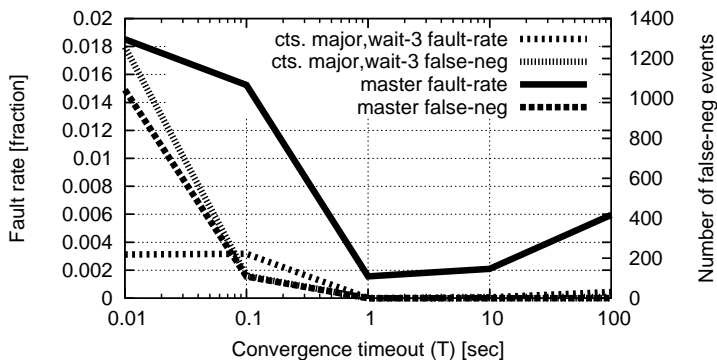

Figure 2.6: Effect of convergence time threshold.

## Performance of fault detection

Protocols today often incorporate thresholds (such as BGP’s MRAI timer) to rate-limit updates. To evaluate the level of protection our scheme provides against unstable instances, as well as the ability to distinguish steady-state from transient behavior, we incorporated a configurable timeout parameter ( $T$ ) in fault detection to identify when a route becomes stable. Figure 2.6 shows the tradeoff as this parameter varies between the *false negative rate* (the number of times a non-buggy instance is treated as buggy), and the *fault rate* (i.e., the false positive rate of the voter, or the fraction of time a buggy route is treated as non-buggy). We found that as  $T$  increases, the false negative rate decreases, as larger values of  $T$  reduce the probability that transient changes will be considered when voting. The false negative rate does not vary among different voting strategies, as fault detection is only performed on steady-

state outputs, and the algorithmic differences between the strategies disappear when performed on outputs that are not dynamically changing. The fault rate increases with  $T$ , as when a bug does occur, it takes longer to detect it. Interestingly, the fault rate initially decreases with  $T$ ; this happens because for low values of  $T$ , more instances are treated as buggy, giving fewer inputs to the voter and increasing the probability of an incorrect decision. Overall, we found that it was possible to tune  $T$  to simultaneously achieve a low fault rate, low false negative, and low detection time.

### 2.5.2 Processing overhead

We evaluate the overhead of running multiple instances using our hypervisor with both XORP- and Quagga-based instances running on single-core 3 Ghz Intel Xeon machines with 2 GB RAM. We measure the *update pass-through time* as the amount of time from when the BGP replayer sends a routing update to when a resulting routing update is received at the monitor. However, some updates may not trigger routing updates to be sent to neighbors, if the router decides to continue using the same route. To deal with this case, we instrument the software router’s source code to determine the point in time when it decides to retain the same route. We also instrument the kernel to measure the *FIB pass-through time*, as the amount of time from when the BGP replayer sends an update to the time the new route is reflected in the router’s FIB (which is stored as the routing table in the Linux kernel).

Figure 2.7 shows the *pass-through* time required for a routing change to reach the FIB. We replayed a Routeviews update trace and varied the number of Quagga instances from 1 to 31, running atop our router hypervisor on a single-core machine. We found the router hypervisor increases FIB pass-through time by 0.08% on average, to 0.06 seconds. Our router hypervisor implementation runs in user space, instead of directly in the kernel, and with a kernel-based implementation this overhead would be further reduced. Increasing the number of instances to 3 incurred an additional

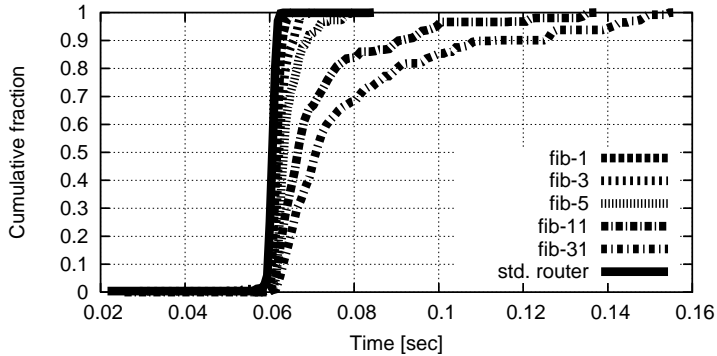

Figure 2.7: BTR pass-through time.

1.7% increase, and to 5 incurred a 4.6% increase. This happens because the multiple instances contend for CPU resources (we found that with multicore CPUs this overhead was substantially lower under heavy loads). To evaluate performance under heavier loads, we increased the rate at which the replayer played back routing updates by a factor of 3000x. Under this heavy load, FIB pass-through times slow for both the standard router and BTR due to increased queuing delays. However, even under these heavy loads, the BTR incurs a delay penalty of less than 23%. To estimate effects on convergence, we also measured the *update pass-through time* as the time required for a received routing change to be sent to neighboring routers. We found this time to be nearly identical to the FIB pass-through time when the MRAI timer was disabled. as updates are sent immediately after updating the FIB. When MRAI was enabled (even when set to 1 second, the lowest possible setting for Quagga), the variation in delay across instances was dwarfed by delay incurred by MRAI. Finally, we found that switching to the master/slave voting strategy reduces pass-through delay, though it slightly increases the fault rate, as discussed previously in Section 2.5.1.

### 2.5.3 Effect on convergence

Next, we study the effect of our design on network-wide convergence. We do this by simulating a network of BTRs (each with eight virtual router instances) across three

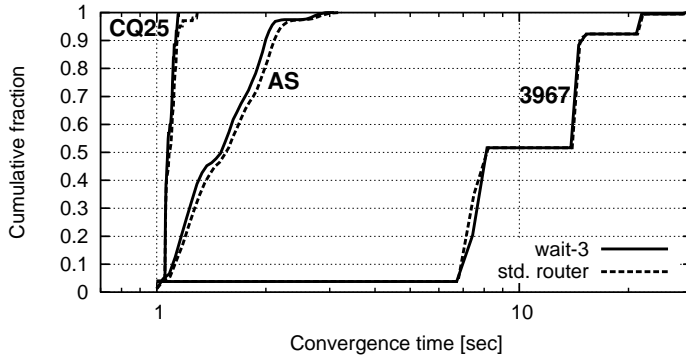

Figure 2.8: Network-wide simulations, per-router convergence delay distribution.

network-level graphs: the entire AS-level topology (labeled *AS* in Figure 2.8) sampled on Jan 20 2008, AS 3967’s internal network topology as collected from Rocketfuel (labeled *3967*), and cliques (labeled *CQ*) of varying sizes (since a clique contains the “worst case” for routing, allowing potential to explore all  $n!$  possible paths in a clique of size  $n$ ). To determine ordering of when BTRs respond, we run our implementation over routing updates, record pass-through times, and replay them within our simulation framework. Since for the master/slave approach there is no effect on network operation unless a bug is triggered (since the slaves only operate as standbys), we focus our evaluation on the other strategies.

We found several key results. First, as shown in Figure 2.8, the voting schemes do not produce any significant change in convergence beyond the delay penalty described in previous sections, as compared to a network only containing standard routers. We found this delay penalty to be much smaller than propagation delays across the network, and to be reduced further when MRAI is activated. As the number of instances increases (up to the number of processor cores), continuous-majority’s delay decreases, because it becomes increasingly likely that one will finish early. The opposite is true for wait-for-consensus, as the delay of the slowest instances becomes increasingly large. Next, while we have thus far considered a *virtual router* level deployment, where voting is performed at each router, we also considered a *virtual network* deployment, where voting is performed at the edges of the network. In our experiments

we ran eight virtual networks and found that this speeds up convergence, as routers do not have to wait for multiple instances to complete processing before forwarding updates. Hence, for small numbers of diverse instances, voting per-router has smaller convergence delay. However, virtual-network approaches require substantially more control overhead than the virtual-router voting schemes. To address this, we found that simple compression schemes [16] that eliminate redundancy across updates could reduce the vast majority of this overhead. Finally, to validate our simulations, we set up small topologies on Emulab [44], injected routing events, and compared with simulations of the same topology. We found no statistically significant difference.

## 2.6 Discussion

For simplicity, this paper discusses the one particular design point. However, our architecture is amenable to deployment on varying levels of granularity:

**Server-based operation:** Instead of running the diverse instances within a single router, their computations may be offloaded to a set of dedicated servers running in the network (*e.g.*, an RCP-like platform [28]). These servers run the router software in virtualized environments, and cross-check the results of routers running within the network. When a buggy result is detected, virtual router instances may be migrated into the network to replace the buggy instance. Alternatively, the servers may be configured to operate in *read-only mode*, such that they may signal alarms to network operators, rather than participate directly in routing.

**Network-wide deployment:** Instead of running instances of individual router software in parallel, ensembles of routers may collectively run entire virtual networks in parallel. Here, the outputs of a router are not merged into a single FIB, or as a single stream of updates sent to its neighbors. Instead, each router maintains a separate FIB for each virtual network, and voting is used at border routers to determine which

virtual network data packets should be sent on. The advantage of this approach is it allows different routing protocols to be used within each virtual network, making it simpler to achieve diversity. For example, OSPF may be run in one network and IS-IS in another. In addition, convergence speed may be improved, as individual physical routers do not have to wait for their instances to reach a majority before sending a routing update.

**Process-level deployment:** Our design runs multiple instances of routing software in parallel, and hence incurs some memory overhead. On many Internet routers this is not an issue, due to low DRAM costs, and the fact that DRAM capacity growth has far exceeded that of routing table growth. That said, if it is still desirable to decrease memory usage, router software may be modified to vote on a shared RIB instead of a FIB. We found the RIB is by far the largest source of memory usage in both Quagga and XORP, incurring 99.3% of total memory usage. Voting on a shared RIB would reduce this overhead by eliminating the need to store separate copies of the RIB across router instances. Here, voting could be performed across multiple routing daemons (e.g., multiple BGP processes within a single instance of Cisco IOS) to construct a single shared RIB. In addition to reducing memory usage, finer-grained diversity may speed reaction (by only cloning and restarting individual processes or threads), and finer-grained control (during times of load, only mission-critical components may be cloned to reduce resource usage). However, code development may become more challenging, since this approach relies on knowing which parts of code are functionally equivalent. To address this, router software could be written to a common API, to allow replication and composition of modules from different code bases while sharing state.

**Leveraging existing redundancy:** Instead of running multiple instances in parallel, a router may be able to leverage redundant executions taking place at other routers in the network. For example, networks often provision redundant network

equipment to protect against physical failures. For example, the VRRP [58] protocol allows multiple routers to act collectively as a single router. Our architecture is amenable to leveraging physical redundancy, as the multiple instances may be deployed across the redundant router instances. In addition, all routers in the ISP compute the same *egress set* of BGP routes that are “equal” according to the first few steps of the decision process that deal with BGP attributes [47, 28]. To leverage this redundancy, it may be possible to extend our architecture to support voting across multiple router’s egress sets.

## 2.7 Related Work

Software and data diversity has been widely applied in other areas of computing, including increasing server reliability [33], improving resilience to worm propagation [80], building survivable Internet services [62], making systems secure against vulnerabilities [39], building survivable overlay networks [110], building fault tolerant networked file systems [30], protecting private information [108], and recovering from memory errors [20]. Techniques have also been developed to minimize computational overhead by eliminating redundant executions and redundant memory usage across parallel instances [111, 56].

However as discussed in Section 2.1.3, routing software presents new challenges for SDD (e.g., routers must react quickly to network changes, have vast configuration spaces and execution paths, rely on distributed operations), as well as new opportunities to customize SDD (routers have small dependence on past history, can achieve the same objectives in different ways, have well-defined interfaces). We address these challenges and opportunities in our design. There has also been work studying router bugs and their effects [107, 74], and our design is inspired by these measurement studies. Also, [27] used a graph-theoretic treatment to study the potential benefits of

diversity across physical routers (as opposed to diversity within a router). As work dealing with misconfigurations [46, 47] and traditional fail-stop failures [15, 78, 75, 58] becomes deployed we envision router bugs will make up an increasingly significant roadblock in improving network availability.

Our work can be contrasted to techniques which attempt to prevent bugs by formally verifying the code. These techniques are typically limited to small codebases, and often require manual efforts to create models of program behavior. For example, with manual intervention, a small operating system kernel was formally verified [69]. For routing, work has been done on languages to model protocol behavior (*e.g.*, [55]), however the focus of this work is on algorithmic behaviors of the protocol, as opposed to other possible places where a bug can be introduced. In contrast, our approach leverages a small and low-complexity hypervisor, which we envision being possible to formally verify.

Our design leverages router virtualization to maintain multiple diverse instances. Router virtualization is an emerging trend gaining increased attention, as well as support in commercial routers. In addition, our design is complementary to use of models of router behavior [46, 47] and control-plane consistency checks [102, 83], as these models/checks can be run in place of one or more of the router virtual instances. Finally, systems such as MARE (Multiple Almost-Redundant Executions) [111] and the Difference Engine [56] focus on reducing overheads from replication. MARE runs a single instruction stream most of the time, and only runs redundant instruction streams when necessary. The Difference Engine attains substantial savings in memory usage across VMs, through use of sub-page level sharing and in-core memory compression. These techniques may be used to further reduce overheads of our design.

## 2.8 Summary

Implementation errors in routing software harm availability, security, and correctness of network operation. In this chapter, we described how to improve resilience of networks to bugs by applying Software and Data Diversity (SDD) techniques to router design. Although these techniques have been widely used in other areas of computing, applying them to routing introduces new challenges and opportunities, which we address in our design. This chapter takes an important first step towards addressing these problems by demonstrating diverse replication is both viable and effective in building robust Internet routers. An implementation of our design shows improved robustness to router bugs with some tolerable additional delay.

# Chapter 3

## Decoupling the Logical IP-layer

## Topology from the Physical

## Topology with VROOM

### 3.1 Introduction

In the previous chapter we presented the bug-tolerant router which masks bugs in router software. While providing a more reliable router, the bug-tolerant router is still plagued by the same problems of today's routers – that the distributed route selection process causes disruption and that there is considerable human effort in managing a network. In this chapter, we target those two issues.

We focus on network management as it is widely recognized as one of the most important challenges facing the Internet. The cost of the people and systems that manage a network typically exceeds the cost of the underlying nodes and links; in addition, most network outages are caused by operator errors, rather than equipment failures [68]. From routine tasks such as planned maintenance to the less-frequent deployment of new protocols, network operators struggle to provide seamless service

in the face of changes to the underlying network. Handling change is difficult because each change to the physical infrastructure requires a corresponding modification to the logical configuration of the routers—such as reconfiguring the tunable parameters in the routing protocols.

*Logical* refers to IP packet-forwarding functions, while *physical* refers to the physical router equipment (such as line cards and the CPU) that enables these functions. Any inconsistency between the logical and physical configurations can lead to unexpected reachability or performance problems. Furthermore, because of today’s tight coupling between the physical and logical topologies, sometimes logical-layer changes are used purely as a *tool* to handle physical changes more gracefully. A classic example is increasing the link weights in Interior Gateway Protocols to “cost out” a router in advance of planned maintenance [98]. In this case, a change in the logical topology is *not* the goal, rather it is the indirect tool available to achieve the task at hand, and it does so with potential negative side effects.

In this chapter, we argue that breaking the tight coupling between physical and logical configurations can provide a *single*, general abstraction that simplifies network management. Specifically, we propose VROOM (Virtual ROuters On the Move), a new network-management primitive where virtual routers can move freely from one physical router to another. In VROOM, physical routers merely serve as the carrier substrate on which the actual virtual routers operate. VROOM can migrate a virtual router to a different physical router without disrupting the flow of traffic or changing the logical topology, obviating the need to reconfigure the virtual routers while also avoiding routing-protocol convergence delays. For example, if a physical router must undergo planned maintenance, the virtual routers could move (in advance) to another physical router in the same Point-of-Presence (PoP). In addition, edge routers can move from one location to another by virtually re-homing the links that connect to neighboring domains.

Realizing these objectives presents several challenges: (i) *migratable routers*: to make a (virtual) router migratable, its “router” functionality must be separable from the physical equipment on which it runs; (ii) *minimal outages*: to avoid disrupting user traffic or triggering routing protocol reconvergence, the migration should cause no or minimal packet loss; (iii) *migratable links*: to keep the IP-layer topology intact, the links attached to a migrating router must “follow” it to its new location. Fortunately, the third challenge is addressed by recent advances in transport-layer technologies, as discussed in Section 3.2. Our goal, then, is to migrate router functionality from one piece of equipment to another without disrupting the IP-layer topology or the data traffic it carries, and without requiring router reconfiguration.

On the surface, virtual router migration might seem like a straight-forward extension to existing virtual machine migration techniques. This would involve copying the virtual router image (including routing-protocol binaries, configuration files and data-plane state) to the new physical router and freezing the running processes before copying them as well. The processes and data-plane state would then be restored on the new physical router and associated with the migrated links. However, the delays in completing all of these steps would cause unacceptable disruptions for both the data traffic and the routing protocols. For virtual router migration to be viable in practice, packet forwarding should not be interrupted, not even temporarily. In contrast, the control plane can tolerate brief disruptions, since routing protocols have their own retransmission mechanisms. Still, the control plane must restart quickly at the new location to avoid losing protocol adjacencies with other routers and to minimize delay in responding to unplanned network events.

In VROOM, we minimize disruption by leveraging the separation of the control and data planes in modern routers. We introduce a *data-plane hypervisor*—a migration-aware interface between the control and data planes. This unified interface allows us to support migration between physical routers with different data-plane

technologies. VROOM migrates only the control plane, while continuing to forward traffic through the old data plane. The control plane can start running at the new location, and populate the new data plane while updating the old data plane in parallel. During the transition period, the old router redirects routing-protocol traffic to the new location. Once the data plane is fully populated at the new location, link migration can begin. The two data planes operate simultaneously for a period of time to facilitate asynchronous migration of the links.

To demonstrate the generality of our data-plane hypervisor, we present two prototype VROOM routers—one with a software data plane (in the Linux kernel) and the other with a hardware data plane (using a NetFPGA card [79]). Each virtual router runs the Quagga routing suite [6] in an OpenVZ container [5]. Our software extensions consist of three main modules that (i) separate the forwarding tables from the container contexts, (ii) push the forwarding-table entries generated by Quagga into the separate data plane, and (iii) dynamically bind the virtual interfaces and forwarding tables. Our system supports seamless live migration of virtual routers between the two data-plane platforms. Our experiments show that virtual router migration causes no packet loss or delay when the hardware data plane is used, and at most a few seconds of delay in processing control-plane messages.

The remainder of the chapter is structured as follows. Section 3.2 presents background on flexible transport networks and an overview of related work. Next, Section 3.3 discusses how router migration would simplify existing network management tasks, such as planned maintenance and service deployment, while also addressing emerging challenges like power management. We present the VROOM architecture in Section 3.4, followed by the implementation and evaluation in Sections 3.5 and 3.6, respectively. We briefly discuss our on-going work on migration scheduling in Section 3.7 and conclude in Section 3.8.

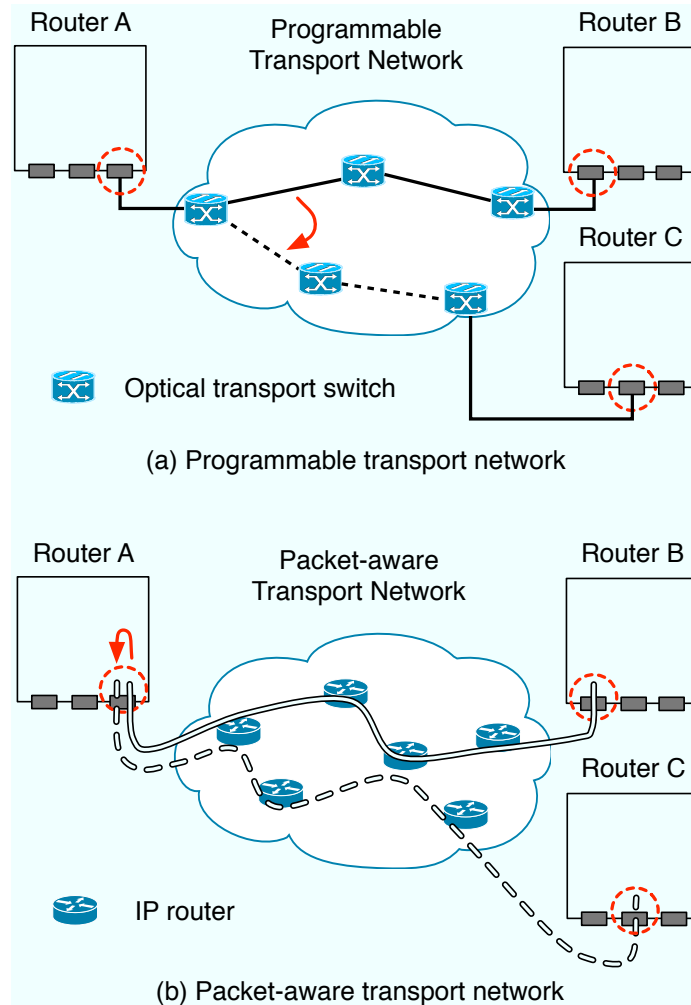

Figure 3.1: Link migration in the transport networks

## 3.2 Background

One of the fundamental requirements of VROOM is “link migration”, i.e., the links of a virtual router should “follow” its migration from one physical node to another. This is made possible by emerging transport network technologies. We briefly describe these technologies before giving an overview of related work.

### 3.2.1 Flexible Link Migration

In its most basic form, a link at the IP layer corresponds to a direct physical link (e.g., a cable), making link migration hard as it involves physically moving link end

point(s). However, in practice, what appears as a direct link at the IP layer often corresponds to a series of connections through different network elements at the transport layer. For example, in today’s ISP backbones, “direct” physical links are typically realized by optical transport networks, where an IP link corresponds to a circuit traversing multiple optical switches [34, 104]. Recent advances in *programmable transport networks* [34, 14] allow physical links between routers to be dynamically set up and torn down. For example, as shown in Figure 3.1(a), the link between physical routers A and B is switched through a programmable transport network. By signaling the transport network, the same physical port on router A can be connected to router C after an optical path switch-over. Such path switch-over at the transport layer can be done efficiently, e.g., sub-nanosecond optical switching time has been reported [90]. Furthermore, such switching can be performed across a wide-area network of transport switches, which enables inter-POP link migration.

In addition to *core links* within an ISP, we also want to migrate *access links* connecting customer edge (CE) routers and provider edge (PE) routers, where only the PE end of the links are under the ISP’s control. Historically, access links correspond to a path in the underlying access network, such as a T1 circuit in a time-division multiplexing (TDM) access network. In such cases, the migration of an access link can be accomplished in similar fashion to the mechanism shown in Figure 3.1(a), by switching to a new circuit at the switch directly connected to the CE router. However, in traditional circuit-switched access networks, a dedicated physical port on a PE router is required to terminate each TDM circuit. Therefore, if all ports on a physical PE router are in use, it will not be able to accommodate more virtual routers. Fortunately, as Ethernet emerges as an economical and flexible alternative to legacy TDM services, access networks are evolving to *packet-aware* transport networks [12]. This trend offers important benefits for VROOM by eliminating the need for per-customer physical ports on PE routers. In a packet-aware access network (e.g., a

virtual private LAN service access network), each customer access port is associated with a label, or a “pseudo wire” [26], which allows a PE router to support multiple logical access links on the same physical port. The migration of a pseudo-wire access link involves establishing a new pseudo wire and switching to it at the multi-service switch [12] adjacent to the CE.

Unlike conventional ISP networks, some networks are realized as overlays on top of other ISPs’ networks. Examples include commercial “Carrier Supporting Carrier (CSC)” networks [36], and VINI, a research virtual network infrastructure overlaid on top of National Lambda Rail and Internet2 [100]. In such cases, a single-hop link in the overlay network is actually a multi-hop path in the underlying network, which can be an MPLS VPN (e.g., CSC) or an IP network (e.g., VINI). Link migration in an MPLS transport network involves switching over to a newly established label switched path (LSP). Link migration in an IP network can be done by changing the IP address of the tunnel end point.

### 3.2.2 Related Work

VROOM’s motivation is similar, in part, to that of the RouterFarm work [14], namely, to reduce the impact of planned maintenance by migrating router functionality from one place in the network to another. However, RouterFarm essentially performs a “cold restart”, compared to VROOM’s live (“hot”) migration. Specifically, in RouterFarm router migration is realized by re-instantiating a router instance at the new location, which not only requires router reconfiguration, but also introduces inevitable downtime in both the control and data planes. In VROOM, on the other hand, we perform *live* router migration without reconfiguration or discernible disruption.

Recent advances in virtual machine technologies and their live migration capabilities [38, 5] have been leveraged in server-management tools, primarily in data centers. For example, Sandpiper [106] automatically migrates virtual servers across

a pool of physical servers to alleviate hotspots. Usher [77] allows administrators to express a variety of policies for managing clusters of virtual servers. Remus [40] uses asynchronous virtual machine replication to provide high availability to server in the face of hardware failures. In contrast, VROOM focuses on leveraging live migration techniques to simplify management in the networking domain.

Network virtualization has been proposed in various contexts. Early work includes the “switchlets” concept, in which ATM switches are partitioned to enable dynamic creation of virtual networks [99]. More recently, the CABO architecture proposes to use virtualization as a means to enable multiple service providers to share the same physical infrastructure [48]. Outside the research community, router virtualization has already become available in several forms in commercial routers [37, 61]. In VROOM, we take an additional step not only to virtualize the router functionality, but also to decouple the virtualized router from its physical host and enable it to migrate.

VROOM also relates to recent work on minimizing transient routing disruptions during planned maintenance. A measurement study of a large ISP showed that more than half of routing changes were planned in advance [59]. Network operators can limit the disruption by reconfiguring the routing protocols to direct traffic away from the equipment undergoing maintenance [98, 52]. In addition, extensions to the routing protocols can allow a router to continue forwarding packets in the data plane while reinstalling or rebooting the control-plane software [93, 32]. However, these techniques require changes to the logical configuration or the routing software, respectively. In contrast, VROOM hides the effects of physical topology changes in the first place, obviating the need for point solutions that increase system complexity while enabling new network-management capabilities, as discussed in the next section.

### 3.3 Network Management Tasks

In this section, we present three case studies of the applications of VROOM. We show that the separation between physical and logical, and the router migration capability enabled by VROOM, can greatly simplify existing network-management tasks. It can also provide network-management solutions to other emerging challenges. We explain why the existing solutions (in the first two examples) are not satisfactory and outline the VROOM approach to addressing the same problems.

#### 3.3.1 Planned Maintenance

Planned maintenance is a hidden fact of life in every network. However, the state-of-the-art practices are still unsatisfactory. For example, software upgrades today still require rebooting the router and re-synchronizing routing protocol states from neighbors (e.g., BGP routes), which can lead to outages of 10-15 minutes [14]. Different solutions have been proposed to reduce the impact of planned maintenance on network traffic, such as “costing out” the equipment in advance. Another example is the RouterFarm approach of removing the static binding between customers and access routers to reduce service disruption time while performing maintenance on access routers [14]. However, we argue that neither solution is satisfactory, since maintenance of *physical* routers still requires changes to the *logical* network topology, and requires (often human interactive) reconfigurations and routing protocol reconvergence. This usually implies more configuration errors [68] and increased network instability.

We performed an analysis of planned-maintenance events conducted in a Tier-1 ISP backbone over a one-week period. Due to space limitations, we only mention the high-level results that are pertinent to VROOM here. Our analysis indicates that, among all the planned-maintenance events that have undesirable network impact

today (e.g., routing protocol reconvergence or data-plane disruption), 70% could be conducted without any network impact if VROOM were used. (This number assumes migration between routers with control planes of like kind. With more sophisticated migration strategies, e.g., where a “control-plane hypervisor” allows migration between routers with different control plane implementations, the number increases to 90%.) These promising numbers result from the fact that most planned-maintenance events were hardware related and, as such, did not intend to make any longer-term changes to the logical-layer configurations.

To perform planned maintenance tasks in a VROOM-enabled network, network administrators can simply migrate all the virtual routers running on a physical router to other physical routers before doing maintenance and migrate them back afterwards as needed, without ever needing to reconfigure any routing protocols or worry about traffic disruption or protocol reconvergence.

### 3.3.2 Service Deployment and Evolution

Deploying new services, like IPv6 or IPTV, is the life-blood of any ISP. Yet, ISPs must exercise caution when deploying these new services. First, they must ensure that the new services do not adversely impact existing services. Second, the necessary support systems need to be in place before services can be properly supported. (Support systems include configuration management, service monitoring, provisioning, and billing.) Hence, ISPs usually start with a small trial running in a controlled environment on dedicated equipment, supporting a few early-adopter customers. However, this leads to a “success disaster” when the service warrants wider deployment. The ISP wants to offer seamless service to its existing customers, and yet also restructure their test network, or move the service onto a larger network to serve a larger set of customers. This “trial system success” dilemma is hard to resolve if the *logical* notion of a “network node” remains bound to a specific *physical* router.

VROOM provides a simple solution by enabling network operators to freely migrate virtual routers from the trial system to the operational backbone. Rather than shutting down the trial service, the ISP can continue supporting the early-adopter customers while continuously growing the trial system, attracting new customers, and eventually seamlessly migrating the entire service to the operational network.

ISPs usually deploy such service-oriented routers as close to their customers as possible, in order to avoid backhaul traffic. However, as the services grow, the geographical distribution of customers may change over time. With VROOM, ISPs can easily reallocate the routers to adapt to new customer demands.

### 3.3.3 Power Savings

VROOM not only provides simple solutions to conventional network-management tasks, but also enables new solutions to emerging challenges such as power management. It was reported that in 2000 the total power consumption of the estimated 3.26 million routers in the U.S. was about 1.1 TWh (Tera-Watt hours) [91]. This number was expected to grow to 1.9 to 2.4TWh in the year 2005 by three different projection models [91], which translates into an annual cost of about 178-225 million dollars [81]. These numbers do not include the power consumption of the required cooling systems.

Although designing energy-efficient equipment is clearly an important part of the solution [57], we believe that network operators can also *manage* a network in a more power-efficient manner. Previous studies have reported that Internet traffic has a consistent diurnal pattern caused by human interactive network activities. However, today's routers are surprisingly power-insensitive to the traffic loads they are handling—an idle router consumes over 90% of the power it requires when working at maximum capacity [31]. We argue that, with VROOM, the variations in daily traffic volume can be exploited to reduce power consumption. Specifically, the size of the

physical network can be expanded and shrunk according to traffic demand, by hibernating or powering down the routers that are not needed. The best way to do this today would be to use the “cost-out/cost-in” approach, which inevitably introduces configuration overhead and performance disruptions due to protocol reconvergence.

VROOM provides a cleaner solution: as the network traffic volume decreases at night, virtual routers can be migrated to a smaller set of physical routers and the unneeded physical routers can be shut down or put into hibernation to save power. When the traffic starts to increase, physical routers can be brought up again and virtual routers can be migrated back accordingly. With VROOM, the IP-layer topology stays intact during the migrations, so that power savings do not come at the price of user traffic disruption, reconfiguration overhead or protocol reconvergence. Our analysis of data traffic volumes in a Tier-1 ISP backbone suggests that, even if only migrating virtual routers within the same POP while keeping the same link utilization rate, applying the above VROOM power management approach could save 18%-25% of the power required to run the routers in the network. As discussed in Section 3.7, allowing migration across different POPs could result in more substantial power savings.

### 3.4 VROOM Architecture

In this section, we present the VROOM architecture. We first describe the three building-blocks that make virtual router migration possible—router virtualization, control and data plane separation, and dynamic interface binding. We then present the VROOM router migration process. Unlike regular servers, modern routers typically have physically separate control and data planes. Leveraging this unique property, we introduce a *data-plane hypervisor* between the control and data planes that enables virtual routers to migrate across different data-plane platforms. We describe

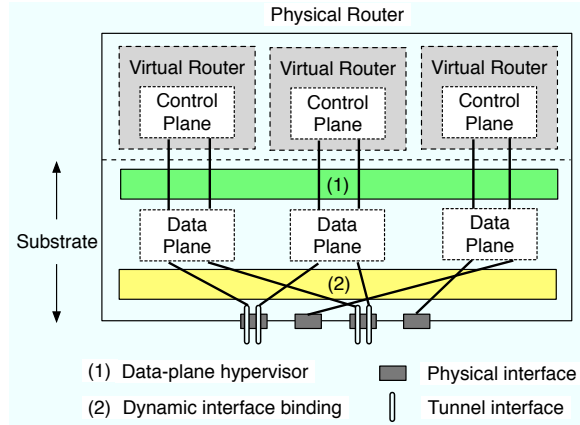

Figure 3.2: The architecture of a VROOM router

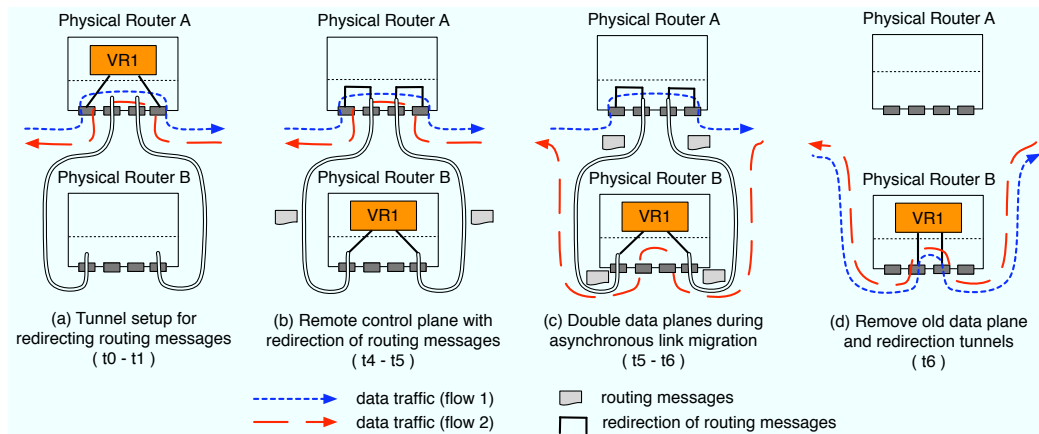

Figure 3.3: VROOM's novel router migration mechanisms (the times at the bottom of the subfigures correspond to those in Figure 3.4)

in detail the three migration techniques that minimize control-plane downtime and eliminate data-plane disruption—data-plane cloning, remote control plane, and double data planes.

### 3.4.1 Making Virtual Routers Migratable

Figure 3.2 shows the architecture of a VROOM router that supports virtual router migration. It has three important features that make migration possible: router virtualization, control and data plane separation, and dynamic interface binding, all of which already exist in some form in today's high-end commercial routers.

**Router Virtualization:** A VROOM router partitions the resources of a physical router to support multiple *virtual router* instances. Each virtual router runs independently with its own control plane (e.g., applications, configurations, routing protocol instances and routing information base (RIB)) and data plane (e.g., interfaces and forwarding information base (FIB)). Such *router virtualization* support is already available in some commercial routers [37, 61]. The isolation between virtual routers makes it possible to migrate one virtual router without affecting the others.

**Control and Data Plane Separation:** In a VROOM router, the control and data planes run in *separate* environments. As shown in Figure 3.2, the control planes of virtual routers are hosted in separate “containers” (or “virtual environments”), while their data planes reside in the *substrate*, where each data plane is kept in separate data structures with its own state information, such as FIB entries and access control lists (ACLs). Similar separation of control and data planes already exists in today’s commercial routers, with control plane running on the CPU(s) and main memory, while the data plane runs on line cards that have their own computing power (for packet forwarding) and memory (to hold the FIBs). This separation allows VROOM to migrate the control and data planes of a virtual router separately (as discussed in Section 3.4.2 and 3.4.2).

**Dynamic Interface Binding:** To enable router migration and link migration, a VROOM router should be able to *dynamically* set up and change the binding between a virtual router’s FIB and its *substrate interfaces* (which can be physical or tunnel interfaces), as shown in Figure 3.2. Given the existing interface binding mechanism in today’s routers that maps interfaces with virtual routers, VROOM only requires two simple extensions. First, after a virtual router is migrated, this binding needs to be re-established dynamically on the new physical router. This is essentially the same as if this virtual router were just instantiated on the physical router. Second, link migration in a packet-aware transport network involves changing tunnel interfaces in

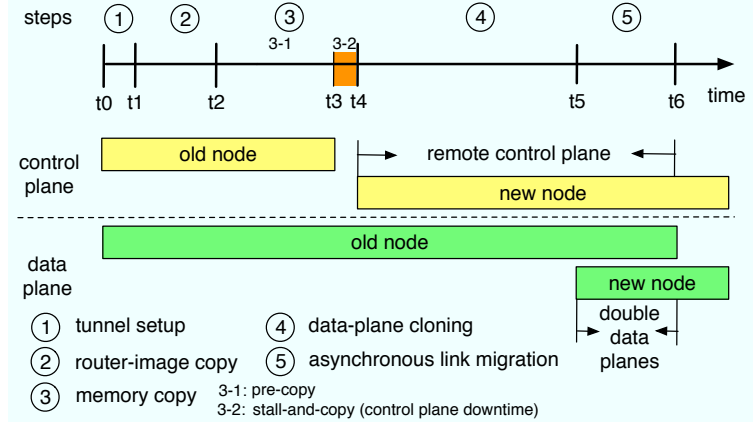

Figure 3.4: VROOM’s router migration process

the router, as shown in Figure 3.1. In this case, the router substrate needs to switch the binding from the old tunnel interface to the new one on-the-fly<sup>1</sup>.

### 3.4.2 Virtual Router Migration Process

Figures 3.3 and 3.4 illustrate the VROOM virtual router migration process. The first step in the process involves establishing tunnels between the source physical router A and destination physical router B of the migration (Figure 3.3(a)). These tunnels allow the control plane to send and receive routing messages after it is migrated (steps 2 and 3) but before link migration (step 5) completes. They also allow the migrated control plane to keep its data plane on A up-to-date (Figure 3.3(b)). Although the control plane will experience a short period of downtime at the end of step 3 (memory copy), the data plane continues working during the entire migration process. In fact, after step 4 (data-plane cloning), the data planes on both A and B can forward traffic simultaneously (Figure 3.3(c)). With these double data planes, links can be migrated from A to B in an asynchronous fashion (Figure 3.3(c) and (d)), after which the data plane on A can be disabled (Figure 3.4). We now describe the migration mechanisms in greater detail.

<sup>1</sup>In the case of a programmable transport network, link migration happens inside the transport network and is transparent to the routers.

## Control-Plane Migration

Two things need to be taken care of when migrating the control plane: the *router image*, such as routing-protocol binaries and network configuration files, and the *memory*, which includes the states of all the running processes. When copying the router image and memory, it is desirable to minimize the total migration time, and more importantly, to minimize the control-plane downtime (i.e., the time between when the control plane is check-pointed on the source node and when it is restored on the destination node). This is because, although routing protocols can usually tolerate a brief network glitch using retransmission (e.g., BGP uses TCP retransmission, while OSPF uses its own reliable retransmission mechanism), a long control-plane outage can break protocol adjacencies and cause protocols to reconverge.

We now describe how VROOM leverages virtual machine (VM) migration techniques to migrate the control plane in steps 2 (router-image copy) and 3 (memory copy) of its migration process, as shown in Figure 3.4.

Unlike general-purpose VMs that can potentially be running completely different programs, virtual routers from the same vendor run the same (usually small) set of programs (e.g., routing protocol suites). VROOM assumes that the same set of binaries are already available on every physical router. Before a virtual router is migrated, the binaries are locally copied to its file system on the destination node. Therefore, only the router configuration files need to be copied over the network, reducing the total migration time (as local-copy is usually faster than network-copy).

The simplest way to migrate the memory of a virtual router is to check-point the router, copy the memory pages to the destination, and restore the router, a.k.a. *stall-and-copy* [5]. This approach leads to downtime that is proportional to the memory size of the router. A better approach is to add an iterative *pre-copy* phase before the final stall-and-copy [38], as shown in Figure 3.4. All pages are transferred in the first round of the pre-copy phase, and in the following rounds, only pages that

were modified during the previous round are transferred. This pre-copy technique reduces the number of pages that need to be transferred in the stall-and-copy phase, reducing the control plane downtime of the virtual router (i.e., the control plane is only “frozen” between t3 and t4 in Figure 3.4).

### Data-Plane Cloning

The control-plane migration described above could be extended to migrate the data plane, i.e., copy all data-plane states over to the new physical node. However, this approach has two drawbacks. First, copying the data-plane states (e.g., FIB and ACLs) is unnecessary and wasteful, because the information that is used to generate these states (e.g., RIB and configuration files) is already available in the control plane. Second, copying the data-plane state directly can be difficult if the source and destination routers use different data-plane technologies. For example, some routers may use TCAM (ternary content-addressable memory) in their data planes, while others may use regular SRAM. As a result, the data structures that hold the state may be different.

VROOM formalizes the interface between the control and data planes by introducing a *data-plane hypervisor*, which allows a migrated control plane to re-instantiate the data plane on the new platform, a process we call **data-plane cloning**. That is, only the control plane of the router is actually migrated. Once the control plane is migrated to the new physical router, it *clones* its original data plane by repopulating the FIB using its RIB and reinstalling ACLs and other data-plane states<sup>2</sup> through the data-plane hypervisor (as shown in Figure 3.2). The data-plane hypervisor provides a unified interface to the control plane that hides the heterogeneity of the underlying

---

<sup>2</sup>Data dynamically collected in the old data plane (such as NetFlow) can be copied and merged with the new one. Other path-specific statistics (such as queue length) will be reset as the previous results are no longer meaningful once the physical path changes.

ing data-plane implementations, enabling virtual routers to migrate between different types of data planes.

### Remote Control Plane

As shown in Figure 3.3(b), after VR1's control plane is migrated from A to B, the natural next steps are to repopulate (clone) the data plane on B and then migrate the links from A to B. Unfortunately, the creation of the new data plane can not be done instantaneously, primarily due to the time it takes to install FIB entries. Installing one FIB entry typically takes between one hundred and a few hundred microseconds [23]; therefore, installing the full Internet BGP routing table (about 250k routes) could take over 20 seconds. During this period of time, although data traffic can still be forwarded by the old data plane on A, all the routing instances in VR1's control plane can no longer send or receive routing messages. The longer the control plane remains unreachable, the more likely it will lose its protocol adjacencies with its neighbors.

To overcome this dilemma, A's substrate starts redirecting all the routing messages destined to VR1 to B at the end of the control-plane migration (time t4 in Figure 3.4). This is done by establishing a tunnel between A and B for each of VR1's substrate interfaces. To avoid introducing any additional downtime in the control plane, these tunnels are established before the control-plane migration, as shown in Figure 3.3(a). With this redirection mechanism, VR1's control plane not only can exchange routing messages with its neighbors, it can also act as the **remote control plane** for its old data plane on A and continue to update the old FIB when routing changes happen.

### Double Data Planes

In theory, at the end of the data-plane cloning step, VR1 can switch from the old data plane on A to the new one on B by migrating all its links from A to B simultane-

ously. However, performing accurate synchronous link migration across all the links is challenging, and could significantly increase the complexity of the system (because of the need to implement a synchronization mechanism).

Fortunately, because VR1 has **two** data planes ready to forward traffic at the end of the data-plane cloning step (Figure 3.4), the migration of its links does not need to happen all at once. Instead, each link can be migrated independent of the others, in an asynchronous fashion, as shown in Figure 3.3(c) and (d). First, router B creates a new *outgoing* link to each of VR1’s neighbors, while all data traffic continues to flow through router A. Then, the *incoming* links can be safely migrated asynchronously, with some traffic starting to flow through router B while the remaining traffic still flows through router A. Finally, once all of VR1’s links are migrated to router B, the old data plane and outgoing links on A, as well as the temporary tunnels, can be safely removed.

## 3.5 Prototype Implementation

In this section, we present the implementation of two VROOM prototype routers. The first is built on commodity PC hardware and the Linux-based virtualization solution OpenVZ [5]. The second is built using the same software but utilizing the NetFPGA platform [79] as the hardware data plane. We believe the design presented here is readily applicable to commercial routers, which typically have the same clean separation between the control and data planes.

Our prototype implementation consists of three new programs, as shown in Figure 3.5. These include `virtd`, to enable packet forwarding outside of the virtual environment (control and data plane separation); `shadowd`, to enable each VE to install routes into the FIB; and `bindd` (data plane cloning), to provide the bindings between the physical interfaces and the virtual interfaces and FIB of each VE (data-plane

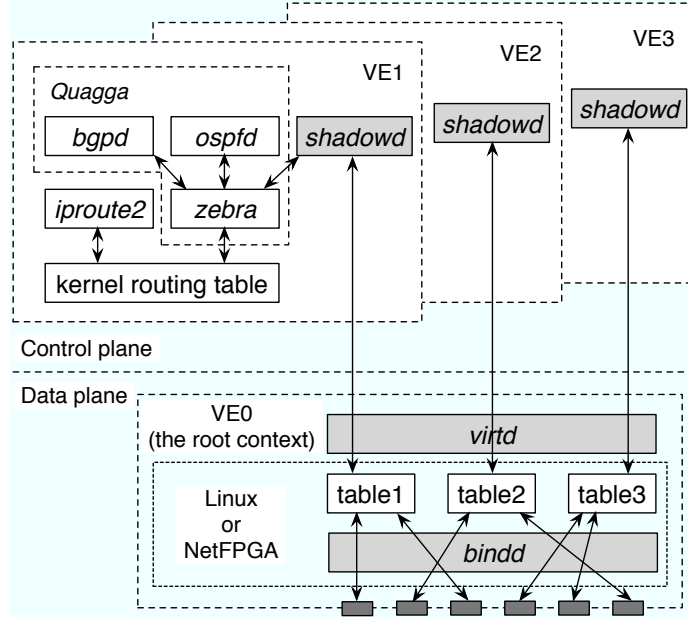

Figure 3.5: The design of the VROOM prototype routers (with two types of data planes)

hypervisor). We first discuss the mechanisms that enable virtual router migration in our prototypes and then present the additional mechanisms we implemented that realize the migration.

### 3.5.1 Enabling Virtual Router Migration

We chose to use OpenVZ [5], a Linux-based OS-level virtualization solution, as the virtualization environment for our prototypes. As running multiple operating systems for different virtual routers is unnecessary, the lighter-weight OS-level virtualization is better suited to our need than other virtualization techniques, such as full virtualization and para-virtualization. In OpenVZ, multiple virtual environments (VEs) running on the same host share the same kernel, but have separate virtualized resources such as name spaces, process trees, devices, and network stacks. OpenVZ also provides live migration capability for running VEs<sup>3</sup>.

<sup>3</sup>The current OpenVZ migration function uses the simple “stall-and-copy” mechanism for memory migration. Including a “pre-copy” stage [38] in the process will reduce the migration downtime.

In the rest of this subsection, we describe in a top-down order the three components of our two prototypes that enable virtual router migration. We first present the mechanism that separates the control and data planes, and then describe the data-plane hypervisor that allows the control planes to update the FIBs in the shared data plane. Finally, we describe the mechanisms that dynamically bind the interfaces with the FIBs and set up the data path.

### **Control and Data Plane Separation**

To mimic the control and data plane separation provided in commercial routers, we move the FIBs out of the VEs and place them in a shared but virtualized data plane, as shown in Figure 3.5. This means that packet forwarding no longer happens within the context of each VE, so it is unaffected when the VE is migrated.

As previously mentioned, we have implemented two prototypes with different types of data planes—a software-based data plane (SD) and a hardware-based data plane (HD). In the SD prototype router, the data plane resides in the root context (or “VE0”) of the system and uses the Linux kernel for packet forwarding. Since the Linux kernel (2.6.18) supports 256 separate routing tables, the SD router virtualizes its data plane by associating each VE with a different kernel routing table as its FIB.

In the HD router implementation, we use the NetFPGA platform configured with the reference router provided by Stanford [79]. The NetFPGA card is a 4-port gigabit ethernet PCI card with a Virtex 2-Pro FPGA on it. With the NetFPGA as the data plane, packet forwarding in the HD router does not use the host CPU, thus more closely resembling commercial router architectures. The NetFPGA reference router does not currently support virtualization. As a result, our HD router implementation is currently limited to only one virtual router per physical node.

## Data-Plane Hypervisor

As explained in Section 3.4, VROOM extends the standard control plane/data plane interface to a migration-aware data-plane hypervisor. Our prototype presents a rudimentary data-plane hypervisor implementation which only supports FIB updates. (A full-fledged data-plane hypervisor would also allow the configuration of other data plane states.) We implemented the `virtd` program as the data-plane hypervisor. `virtd` runs in the VE0 and provides an interface for virtual routers to install/remove routes in the shared data plane, as shown in Figure 3.5. We also implemented the `shadowd` program that runs inside each VE and pushes route updates from the control plane to the FIB through `virtd`.

We run the Quagga routing software suite [6] as the control plane inside each VE. Quagga supports many routing protocols, including BGP and OSPF. In addition to the included protocols, Quagga provides an interface in `zebra`, its routing manager, to allow the addition of new protocol daemons. We made use of this interface to implement `shadowd` as a client of `zebra`. `zebra` provides clients with both the ability to notify `zebra` of route changes and to be notified of route changes. As `shadowd` is not a routing protocol but simply a shadowing daemon, it uses only the route redistribution capability. Through this interface, `shadowd` is notified of any changes in the RIB and immediately mirrors them to `virtd` using remote procedure calls (RPCs). Each `shadowd` instance is configured with a unique ID (e.g., the ID of the virtual router), which is included in every message it sends to `virtd`. Based on this ID, `virtd` can correctly install/remove routes in the corresponding FIB upon receiving updates from a `shadowd` instance. In the SD prototype, this involves using the Linux `iproute2` utility to set a routing table entry. In the HD prototype, this involves using the device driver to write to registers in the NetFPGA.

## Dynamic Interface Binding

With the separation of control and data planes, and the sharing of the same data plane among multiple virtual routers, the data path of each virtual router must be set up properly to ensure that (i) data packets can be forwarded according to the right FIB, and (ii) routing messages can be delivered to the right control plane.

We implemented the `bindd` program that meets these requirements by providing two main functions. The first is to set up the mapping between a virtual router's substrate interfaces and its FIB after the virtual router is instantiated or migrated, to ensure correct packet forwarding. (Note that a virtual router's substrate interface could be either a dedicated physical interface or a tunnel interface that shares the same physical interface with other tunnels.) In the SD prototype, `bindd` establishes this binding by using the routing policy management function (i.e., "ip rule") provided by the Linux *iproute2* utility. As previously mentioned, the HD prototype is currently limited to a single table. Once NetFPGA supports virtualization, a mechanism similar to the "ip rule" function can be used to bind the interfaces with the FIBs.

The second function of `bindd` is to bind the substrate interfaces with the virtual interfaces of the control plane. In both prototypes, this binding is achieved by connecting each pair of substrate and virtual interfaces to a different bridge using the Linux *brctl* utility. In the HD prototype, each of the four physical ports on the NetFPGA is presented to Linux as a separate physical interface, so packets destined to the control plane of a local VE are passed from the NetFPGA to Linux through the corresponding interface.

### 3.5.2 Realizing Virtual Router Migration

The above mechanisms set the foundation for VROOM virtual router migration in the OpenVZ environment. We now describe the implementations of data-plane cloning, remote control plane, and double data planes.

Although migration is transparent to the routing processes running in the VE, `shadowd` needs to be notified at the end of the control plane migration in order to start the “data plane cloning”. We implemented a function in `shadowd` that, when called, triggers `shadowd` to request `zebra` to resend all the routes and then push them down to `virtd` to repopulate the FIB. Note that `virtd` runs on a fixed (private) IP address and a fixed port on each physical node. Therefore, after a virtual router is migrated to a new physical node, the route updates sent by its `shadowd` can be seamlessly routed to the local `virtd` instance on the new node.

To enable a migrated control plane to continue updating the old FIB (i.e., to act as a “remote control plane”), we implemented in `virtd` the ability to forward route updates to another `virtd` instance using the same RPC mechanism that is used by `shadowd`. As soon as virtual router VR1 is migrated from node A to node B, the migration script notifies the `virtd` instance on B of A’s IP address and VR1’s ID. B’s `virtd`, besides updating the new FIB, starts forwarding the route updates from VR1’s control plane to A, whose `virtd` then updates VR1’s old FIB. After all of VR1’s links are migrated, the old data plane is no longer used, so B’s `virtd` is notified to stop forwarding updates. With B’s `virtd` updating both the old and new FIBs of VR1 (i.e., the “double data planes”), the two data planes can forward packets during the asynchronous link migration process.

Note that the data-plane hypervisor implementation makes the the control planes unaware of the details of a particular underlying data plane. As a result, migration can occur between any combination of our HD and SD prototypes (i.e. SD to SD, HD to HD, SD to HD, and HD to SD).

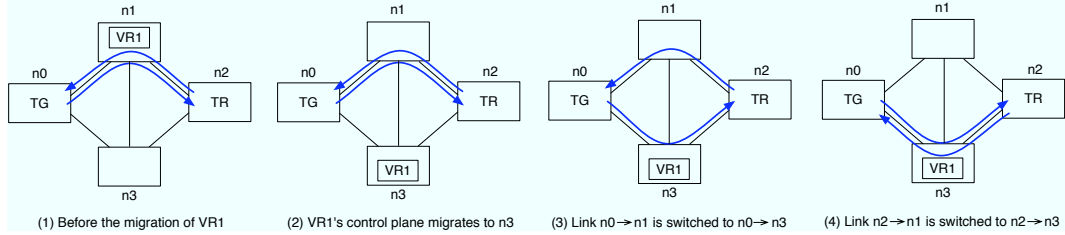

Figure 3.6: The diamond testbed and the experiment process

## 3.6 Evaluation

In this section, we evaluate the performance of VROOM using our SD and HD prototype routers. We first measure the performance of the basic functions of the migration process individually, and then place a VROOM router in a network and evaluate the effect its migration has on the data and control planes. Specifically, we answer the following two questions:

1. *What is the impact of virtual router migration on data forwarding?* Our evaluation shows that it is important to have bandwidth isolation between migration traffic and data traffic. With separate bandwidth, migration based on an HD router has **no** performance impact on data forwarding. Migration based on a SD router introduces minimal delay increase and no packet loss to data traffic.

2. *What is the impact of virtual router migration on routing protocols?* Our evaluation shows that a virtual router running only OSPF in an Abilene-topology network can support 1-second OSPF *hello-interval* without losing protocol adjacencies during migration. The same router loaded with an additional full Internet BGP routing table can support a minimal OSPF *hello-interval* of 2 seconds without losing OSPF or BGP adjacencies.

### 3.6.1 Methodology

Our evaluation involved experiments conducted in the Emulab testbed [44]. We primarily used PC3000 machines as the physical nodes in our experiments. The PC3000

is an Intel Xeon 3.0 GHz 64-bit platform with 2GB RAM and five Gigabit Ethernet NICs. For the HD prototype, each physical node was additionally equipped with a NetFPGA card. All nodes in our experiments were running an OpenVZ patched Linux kernel 2.6.18-ovz028stab049.1. For a few experiments we also used the lower performance PC850 physical nodes, built on an Intel Pentium III 850MHz platform with 512MB RAM and five 100Mbps Ethernet NICs.

We used three different testbed topologies in our experiments:

**The diamond testbed:** We use the 4-node diamond-topology testbed (Figure 3.6) to evaluate the performance of individual migration functions and the impact of migration on the data plane. The testbed has two different configurations, which have the same type of machines as physical node n0 and n2, but differ in the hardware on node n1 and n3. In the *SD* configuration, n1 and n3 are regular PCs on which we install our SD prototype routers. In the *HD* configuration, n1 and n3 are PCs each with a NetFPGA card, on which we install our HD prototype routers. In the experiments, virtual router VR1 is migrated from n1 to n3 through link n1→n3.

**The dumbbell testbed:** We use a 6-node dumbbell-shaped testbed to study the bandwidth contention between migration traffic and data traffic. In the testbed, round-trip UDP data traffic is sent between a pair of nodes while a virtual router is being migrated between another pair of nodes. The migration traffic and data traffic are forced to share the same physical link.

**The Abilene testbed:** We use a 12-node testbed (Figure 3.7) to evaluate the impact of migration on the control plane. It has a topology similar to the 11-node Abilene network backbone [11]. The only difference is that we add an additional physical node (Chicago-2), to which the virtual router on Chicago-1 (V5) is migrated. Figure 3.7 shows the initial topology of the virtual network, where 11 virtual routers (V1 to V11) run on the 11 physical nodes (except Chicago-2) respectively.

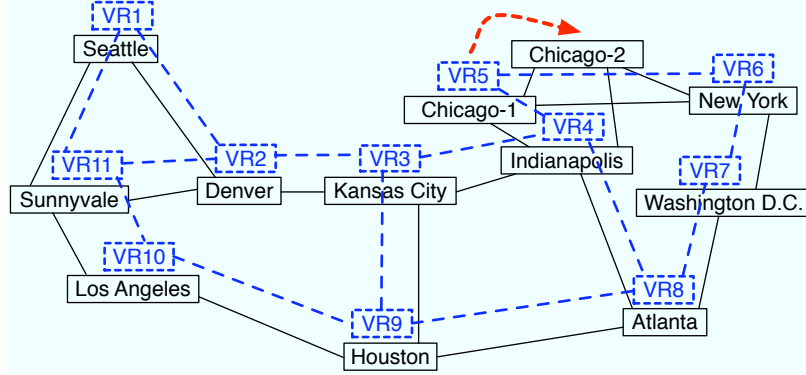

Figure 3.7: The Abilene testbed

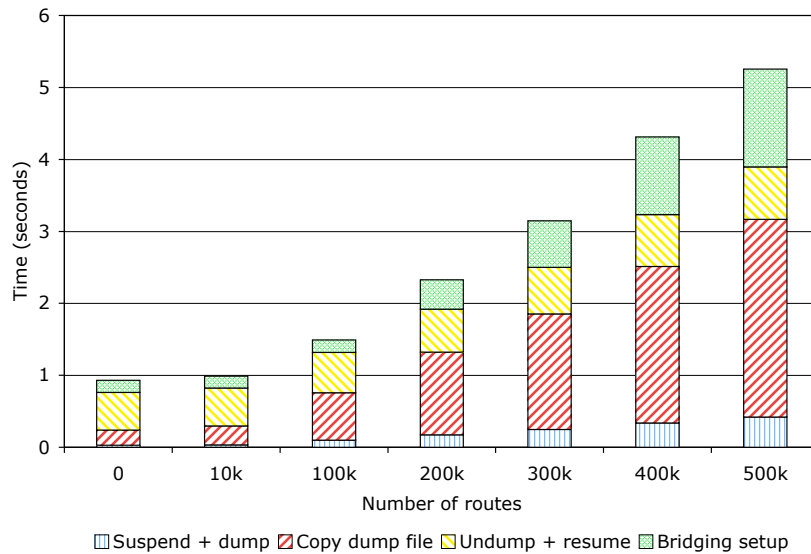

Figure 3.8: Virtual router memory-copy time with different numbers of routes

### 3.6.2 Performance of Migration Steps

In this subsection, we evaluate the performance of the two main migration functions of the prototypes—memory copy and FIB repopulation.

**Memory copy:** To evaluate memory copy time relative to the memory usage of the virtual router, we load the `ospfd` in VR1 with different numbers of routes. Table 3.1 lists the respective memory dump file sizes of VR1. Figure 3.8 shows the total time it takes to complete the memory-copy step, including (1) suspend/dump VR1 on n1, (2) copy the dump file from n1 to n3, (3) resume VR1 on n3, and (4) set up the bridging (interface binding) for VR1 on n3. We observe that as the number of routes becomes

Table 3.1: The memory dump file size of virtual router with different numbers of OSPF routes

Routes	0	10k	100k	200k	300k	400k	500k
Size (MB)	3.2	24.2	46.4	58.4	71.1	97.3	124.1

Table 3.2: The FIB repopulating time of the SD and HD prototypes

Data plane type	Software data plane (SD)				Hardware data plane (HD)			
	100	1k	10k	15k	100	1k	10k	15k
FIB update time (sec)	0.1946	1.9318	19.3996	31.2113	0.0008	0.0074	0.0738	0.1106
Total time (sec)	0.2110	2.0880	20.9851	33.8988	0.0102	0.0973	0.9634	1.4399

larger, the time it takes to copy the dump file becomes the dominating factor of the total memory copy time. We also note that when the memory usage becomes large, the bridging setup time also grows significantly. This is likely due to CPU contention with the virtual router restoration process, which happens at the same time.

**FIB repopulation:** We now measure the time it takes VR1 to repopulate the new FIB on n3 after its migration. In this experiment, we configure the virtual router with different numbers of static routes and measure the time it takes to install all the routes into the FIB in the software or hardware data plane. Table 3.2 compares the FIB update time and total time for FIB repopulation. FIB update time is the time `virtd` takes to install route entries into the FIB, while total time also includes the time for `shadowd` to send the routes to `virtd`. Our results show that installing a FIB entry into the NetFPGA hardware (7.4 microseconds) is over 250 times faster than installing a FIB entry into the Linux kernel routing table (1.94 milliseconds). As can be expected the update time increases linearly with the number of routes.

### 3.6.3 Data Plane Impact

In this subsection, we evaluate the influence router migration has on data traffic. We run our tests in both the HD and SD cases and compare the results. We also study the importance of having bandwidth isolation between the migration and data traffic.

### **Zero impact: HD router with separate migration bandwidth**

We first evaluate the data plane performance impact of migrating a virtual router from our HD prototype router. We configure the HD testbed such that the migration traffic from n1 to n3 goes through the direct link n1→n3, eliminating any potential bandwidth contention between the migration traffic and data traffic.

We run the D-ITG traffic generator [41] on n0 and n2 to generate round-trip UDP traffic. Our evaluation shows that, even with the maximum packet rate the D-ITG traffic generator on n0 can handle (sending and receiving 64-byte UDP packets at 91k packets/s), migrating the virtual router VR1 from n1 to n3 (including the control plane migration and link migration) does not have any performance impact on the data traffic it is forwarding—there is no delay increase or packet loss<sup>4</sup>. These results are not surprising, as the packet forwarding is handled by the NetFPGA, whereas the migration is handled by the CPU. This experiment demonstrates that hardware routers with separate migration bandwidth can migrate virtual routers with zero impact on data traffic.

### **Minimal impact: SD router with separate migration bandwidth**

In the SD router case, CPU is the resource that could potentially become scarce during migration, because the control plane and data plane of a virtual router share the same CPU. We now study the case in which migration and packet forwarding together saturate the CPU of the physical node. As with the HD experiments above, we use link n1→n3 for the migration traffic to eliminate any bandwidth contention.

In order to create a CPU bottleneck on n1, we use PC3000 machines on n0 and n2 and use lower performance PC850 machines on n1 and n3. We migrate VR1 from n1 to n3 while sending round-trip UDP data traffic between nodes n0 and n2. We

---

<sup>4</sup>We hard-wire the MAC addresses of adjacent interfaces on each physical nodes to eliminate the need for ARP request/response during link migration.

vary the packet rate of the data traffic from 1k to 30k packets/s and observe the performance impact the data traffic experiences due to the migration. (30k packets/s is the maximum bi-directional packet rate a PC850 machine can handle without dropping packets.)

Somewhat surprisingly, the delay increase caused by the migration is only noticeable when the packet rate is relatively low. When the UDP packet rate is at 5k packets/s, the control plane migration causes sporadic round-trip delay increases up to 3.7%. However, when the packet rate is higher (e.g., 25k packets/s), the change in delay during the migration is negligible ( $< 0.4\%$ ).

This is because the packet forwarding is handled by kernel threads, whereas the OpenVZ migration is handled by user-level processes (e.g., `ssh`, `rsync`, etc.). Although kernel threads have higher priority than user-level processes in scheduling, Linux has a mechanism that prevents user-level processes from starving when the packet rate is high. This explains the delay increase when migration is in progress. However, the higher the packet rate is, the more frequently the user-level migration processes are interrupted, and more frequently the packet handler is called. Therefore, the higher the packet rate gets, the less additional delay the migration processes add to the packet forwarding. This explains why when the packet rate is 25k packets/s, the delay increase caused by migration becomes negligible. This also explains why migration does not cause any packet drops in the experiments. Finally, our experiments indicate that the link migration does not affect forwarding delay.

### **Reserved migration bandwidth is important**

In [3.6.3](#) and [3.6.3](#), migration traffic is given its own link (i.e., has separate bandwidth). Here we study the importance of this requirement and the performance implications for data traffic if it is not met.

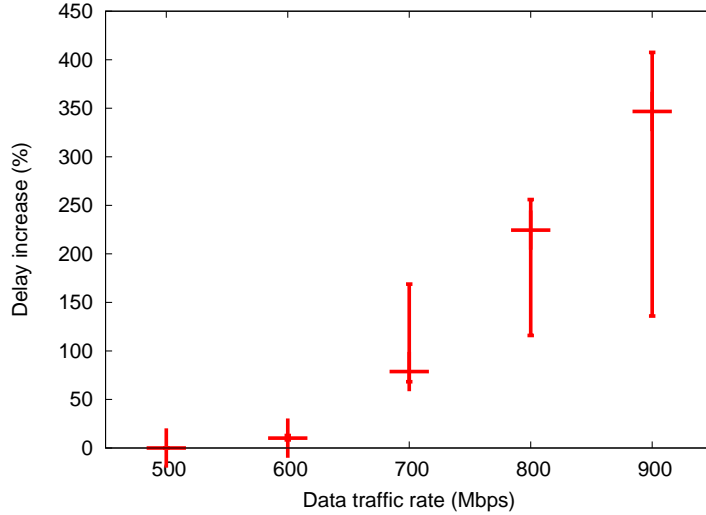

Figure 3.9: Delay increase of the data traffic, due to bandwidth contention with migration traffic

Table 3.3: Packet loss rate of the data traffic, with and without migration traffic

Data traffic rate (Mbps)	500	600	700	800	900
Baseline (%)	0	0	0	0	0.09
w/ migration traffic (%)	0	0	0.04	0.14	0.29

We use the dumbbell testbed in this experiment, where migration traffic and data traffic share the same bottleneck link. We load the `ospfd` of a virtual router with 250k routes. We start the data traffic rate from 500 Mbps, and gradually increase it to 900 Mbps. Because OpenVZ uses TCP (`scp`) for memory copy, the migration traffic only receives the left-over bandwidth of the UDP data traffic. As the available bandwidth decreases to below 300 Mbps, the migration time increases, which translates into a longer control-plane downtime for the virtual router.

Figure 3.9 compares the delay increase of the data traffic at different rates. Both the average delay and the delay jitter increase dramatically as the bandwidth contention becomes severe. Table 3.3 compares the packet loss rates of the data traffic at different rates, with and without migration traffic. Not surprisingly, bandwidth contention (i.e., data traffic rate  $\geq 700$  Mbps) causes data packet loss. The above results indicate that in order to minimize the control-plane downtime of the virtual

router, and to eliminate the performance impact to data traffic, operators should provide separate bandwidth for the migration traffic.

### 3.6.4 Control Plane Impact

In this subsection, we investigate the control plane dynamics introduced by router migration, especially how migration affects the protocol adjacencies. We assume a backbone network running MPLS, in which its edge routers run OSPF and BGP, while its core routers run only OSPF. Our results show that, with default timers, protocol adjacencies of both OSPF and BGP are kept intact, and at most one OSPF LSA retransmission is needed in the worst case.

#### Core Router Migration

We configure virtual routers VR1, VR6, VR8 and VR10 on the Abilene testbed (Figure 3.7) as edge routers, and the remaining virtual routers as core routers. By migrating VR5 from physical node Chicago-1 to Chicago-2, we observe the impact of migrating a core router on OSPF dynamics.

**No events during migration:** We first look at the case in which there are no network events during the migration. Our experiment results show that the control-plane downtime of VR5 is between 0.924 and 1.008 seconds, with an average of 0.972 seconds over 10 runs.

We start with the default OSPF timers of Cisco routers: *hello-interval* of 10 seconds and *dead-interval* of 40 seconds. We then reduce the *hello-interval* to 5, 2, and 1 second in subsequent runs, while keeping the *dead-interval* equal to four times the *hello-interval*. We find that the OSPF adjacencies between the migrating VR5 and its neighbors (VR4 and VR6) stay up in all cases. Even in the most restrictive 1-second *hello-interval* case, at most one OSPF hello message is lost and VR5 comes back up on Chicago-2 before its neighbors' dead timers expire.

**Events happen during migration:** We then investigate the case in which there are events during the migration and the migrating router VR5 misses the LSAs triggered by the events. We trigger new LSAs by flapping the link between VR2 and VR3. We observe that VR5 misses an LSA when the LSA is generated during VR5's 1-second downtime. In such a case, VR5 gets a retransmission of the missing LSA 5 seconds later, which is the default LSA *retransmit-interval*.

We then reduce the LSA *retransmit-interval* from 5 seconds to 1 second, in order to reduce the time that VR5 may have a stale view of the network. This change brings down the maximum interval between the occurrence of a link flap and VR5's reception of the resulting LSA to 2 seconds (i.e., the 1 second control plane downtime plus the 1 second LSA *retransmit-interval*).

## Edge Router Migration

Here we configure VR5 as the fifth edge router in the network that runs BGP in addition to OSPF. VR5 receives a full Internet BGP routing table with 255k routes (obtained from RouteViewson Dec 12, 2007) from an eBGP peer that is not included in Figure 3.7, and it forms an iBGP full mesh with the other four edge routers.

With the addition of a full BGP table, the memory dump file size grows from 3.2 MB to 76.0 MB. As a result, it takes longer to suspend/dump the virtual router, copy over its dump file, and resume it. The average downtime of the control plane during migration increases to between 3.484 and 3.594 seconds, with an average of 3.560 seconds over 10 runs. We observe that all of VR5's BGP sessions stay intact during its migration. The minimal integer *hello-interval* VR5 can support without breaking its OSPF adjacencies during migration is 2 seconds (with *dead-interval* set to 8 seconds). In practice, ISPs are unlikely to set the timers much lower than the default values, in order to shield themselves from faulty links or equipment.

## 3.7 Migration Scheduling

This paper primarily discusses the question of migration mechanisms (“how to migrate”) for VROOM. Another important question is the migration scheduling (“where to migrate”). Here we briefly discuss the constraints that need to be considered when scheduling migration and several optimization problems that are part of our ongoing work on VROOM migration scheduling.

When deciding where to migrate a virtual router, several physical constraints need to be taken into consideration. First of all, an “eligible” destination physical router for migration must use a *software platform* compatible with the original physical router, and have similar (or greater) *capabilities* (such as the number of access control lists supported). In addition, the destination physical router must have sufficient resources available, including *processing power* (whether the physical router is already hosting the maximum number of virtual routers it can support) and *link capacity* (whether the links connected to the physical router have enough unused bandwidth to handle the migrating virtual router’s traffic load). Furthermore, the *redundancy* requirement of the virtual router also needs to be considered—today a router is usually connected to two different routers (one as primary and the other as backup) for redundancy. If the primary and backup are migrated to the same node, physical redundancy will be lost.

Fortunately, ISPs typically leave enough “head room” in link capacities to absorb increased traffic volume. Additionally, most ISPs use routers from one or two vendors, with a small number of models, which leaves a large number of eligible physical routers to be chosen for the migration.

Given a physical router that requires maintenance, the question of where to migrate the virtual routers it currently hosts can be formulated as an optimization problem, subject to all the above constraints. Depending on the preference of the operator, different objectives can be used to pick the best destination router, such

as minimizing the overall CPU load of the physical router, minimizing the maximum load of physical links in the network, minimizing the stretch (i.e., latency increase) of virtual links introduced by the migration, or maximizing the reliability of the network (e.g., the ability to survive the failure of any physical node or link). However, finding optimal solutions to these problems may be computationally intractable. Fortunately, simple local-search algorithms should perform reasonably well, since the number of physical routers to consider is limited (e.g., to hundreds or small thousands, even for large ISPs) and finding a “good” solution (rather than an optimal one) is acceptable in practice.

Besides migration scheduling for planned maintenance, we are also working on the scheduling problems of power savings and traffic engineering. In the case of power savings, we take the power prices in different geographic locations into account and try to minimize power consumption with a certain migration granularity (e.g., once every hour, according to the hourly traffic matrices). In the case of traffic engineering, we migrate virtual routers to shift load away from congested physical links.

### 3.8 Summary

VROOM is a new network-management primitive that supports live migration of virtual routers from one physical router to another. To minimize disruptions, VROOM allows the migrated control plane to clone the data-plane state at the new location while continuing to update the state at the old location. VROOM temporarily forwards packets using both data planes to support asynchronous migration of the links. These designs are readily applicable to commercial router platforms. Experiments with our prototype system demonstrate that VROOM does not disrupt the data plane and only briefly freezes the control plane. In the unlikely scenario that a

control-plane event occurs during the freeze, the effects are largely hidden by existing mechanisms for retransmitting routing-protocol messages.

# Chapter 4

## Seamless Edge Link Migration with Router Grafting

### 4.1 Introduction

With VROOM we enable migrating an entire virtual router. While this greatly simplifies many network management tasks, in some instances migrating an entire virtual router is too coarse of a granularity. In this chapter we present a more fine-grained migration mechanism.

In nature, grafting is where a part of one living organism (e.g., tissue from a plant) is removed and fused into another organism. We apply this concept to routers to enable new network-management capabilities which allow network changes to be made with minimal disruption. We call this *router grafting*. With router grafting, we view routers in terms of their parts and enable splitting these parts from one router and merging them into another. This capability makes the view of the network a more fluid one where the topology can readily change, allowing operators to adapt their networks without disruption in the service offered to users. We envision router grafting to eventually be applicable to arbitrary subsets of router resources and/or

protocols. However, in this chapter we take the first step towards this vision by focusing how to “graft” a BGP session and the underlying link from one router to another.

### 4.1.1 A Case for Router Grafting

The ability to adapt the network is an essential component of network management. Unfortunately, today’s routers and routing protocols make change difficult. Changes to the network cause disruption, forcing operators to weigh the benefit of making a change against the potential impact performing the change will have. For example, today, the basic task of rehomeing a BGP session requires shutting down the session, reconfiguring the new router, restarting the session, and exchanging a large amount of routing information typically leading to downtimes of several minutes. Further complicating matters is the fact that service-level agreements with customers often prohibit events that result in downtime without receiving prior approval and scheduling a maintenance window. This hand-cuffs the operator. In this section we provide several motivating examples of why seamless migration is needed and why it would be desirable to do at the level of individual sessions.

**Load balancing across blades in a cluster router:** Today’s high-end routers have modular designs consisting of many cards—processor blades for running routing processes and interface cards for terminating links—spread over multiple chassis. In essence, the router itself is a large distributed system. Load balancing is an important function in distributed systems, and routers are no exception—today’s routers often run near their limits of processing capacity [13]. Unfortunately, routers are not built with load balancing in mind. A BGP session is associated with a routing process on a particular blade upon establishment, making it difficult to shift load to another blade. A common approach used with Web servers is to drain load by directing new requests to other servers and waiting for existing requests to complete. Unfortunately, this

technique is not applicable to routers, since routing sessions run indefinitely and unlike web services have persistent state. However, with the ability to migrate individual sessions, achieving better utilization of the router’s processing capabilities is possible.

**Rehoming a customer:** An ISP homes a customer to a router based on geographic proximity and the availability of a router slot that can accommodate the customer’s request [54]. However, this is done only at the time when a customer initiates service, based on the state of the network at that time. Rehoming might be necessary if the customer upgrades to a new service (such as multicast, IPv6, or advanced QoS or monitoring features) available only on a subset of routers. Rehoming is also necessary when an ISP upgrades or replaces a router and needs to move sessions from the old router to the new one. Customer rehoming involves moving the edge link—which can be done quickly because of recent innovations in layer-two access networks—as well as the BGP session.

**Planned maintenance:** Maintenance is a fact of life for network operators, yet, even though maintenance is planned in advance, little can be done to keep the router running. Consider a simple task of replacing a power supply. The best common practice is for operators to reconfigure the routing protocols to direct traffic away from that router and, once the traffic stops flowing, to take the router offline. Unfortunately, this approach only works for core routers within an ISP where alternate paths are available. At the edge of the network, an attractive alternative would be to graft all of the BGP sessions with neighboring networks to other routers to avoid disruptions in service. Migrating at the level of individual sessions is preferable to migrating all of the sessions and the routing processes as a group, since fine-grain migration allows multiple different routers to absorb only a small amount of extra load during the maintenance interval.

**Traffic engineering:** Traffic engineering is the act of reconfiguring the network to optimize the flow of traffic, to minimize congestion. Today, traffic engineering in-

volves adjusting the routing-protocol parameters to coax the routers into computing new paths that better match the offered traffic, at the expense of transient disruptions during routing convergence. Router grafting enables a new approach to traffic engineering, where certain customers are rehomed to an edge router that better matches the traffic patterns. For example, if most of a customer’s traffic leaves the ISP’s network at a particular location, that customer could be rehomed closer to that egress point. In other words, we no longer need to consider the traffic matrix as fixed when performing traffic engineering—instead, we can change the traffic matrix to better match the backbone topology and routing by having traffic enter the network at a new location.

#### **4.1.2 Challenges and Contributions**

The benefits of router grafting are numerous. However, the design of today’s routers and routing protocols make realizing router grafting challenging. Grafting a BGP session involves (i) migrating the underlying TCP connection, (ii) exchanging routing state, (iii) moving the routing-protocol configuration from one router to another, and (iv) migrating the underlying link. Ideally, all these actions need to be performed in a manner that is completely transparent (i.e., without involving the routers and operators in neighboring networks) and does not disrupt forwarding and routing (i.e., data packets are not dropped and routing adjacencies remain up).

Unfortunately, we cannot simply apply existing techniques for application-level session migration. Moving a BGP session to a different router changes the network topology and hence, the routing decisions at other routers. In particular, the remote end-point of the session must be informed of any routing changes—that is, any differences between the “best routes” chosen by the new and old homing points. Similarly, other routers in the ISP network need to change how they route toward destinations

reachable through that remote end-point—they need to learn that these destinations are now reachable through the new homing location.

In addition, we cannot simply apply our proposed techniques for virtual-router migration (as discussed in Chapter 3), for two main reasons. First, the two physical routers may not be compatible—they may run different routing software (e.g., Cisco, Juniper, Quagga, or XORP). Second, we want to migrate and merge only a single BGP session, not the entire routing process, as many scenarios benefit from finer granularity. Instead, we view virtual-router migration as a complementary management primitive.

Fortunately, extending existing router software to support grafting requires only modest changes. The essential state that must be migrated is often well separated in the code. This makes it possible to export the state from one router and import it to another without much complexity. In this chapter, we present an architecture for realizing router grafting and make the following contributions:

- Introduce the concept of router grafting, and realize an instance of it through BGP session migration. We demonstrate that BGP session migration can be performed in today’s monolithic routing software, without much modification or refactoring of the code. Our fully-automated prototype router-grafting system is built by using and extending Click, Linux, and Quagga.
- Achieve transparency, where the remote BGP session end-point is not modified and is unaware migration is happening. We achieve this by bootstrapping a routing session at the new homing location, with the old router emulating the remote end-point. The new homing point then takes over the role of the old router, sending the necessary routing updates to notify the remote end-point of routing changes.

- Introduce optimizations to nearly eliminate the impact of migration on other routers not directly involved in the migration. We achieve this by capitalizing on the fact that the routers already have much of the routing information they need, and that we know the identity of the old and new homing points.
- Describe an architecture where unplanned routing changes (such as link failures) during the grafting process do not affect correctness, and where packets are delivered successfully even during the migration. At worst, packets temporarily traverse a different path than the control plane advertises—a common situation during routing convergence.
- Present an optimization framework for traffic engineering with router grafting and develop algorithms that determine which traffic end-points should migrate, and where. Our experiments with Internet2 traffic and topology data show that router grafting allows the network to carry at least 25% more traffic (at the same level of performance) over optimizing routing alone.

The remainder of the chapter is organized as follows. Section 4.2 discusses how the operation of BGP makes router grafting challenging. In Section 4.3 we present the router grafting architecture, focusing only on the control plane. Section 4.4 explains how we ensure correct routing and forwarding, even in the face of unplanned routing changes. In Section 4.5 we present our prototype, followed by a discussion of optimizations that reduce the overhead of grafting a BGP session in Section 4.6. We present an evaluation of our prototype and proposed optimizations in Section 4.7. In Section 4.8 we present new algorithms for applying router grafting to traffic engineering along with an evaluation of real traffic on a real network. We wrap up with related work in Section 4.9 and the conclusion in Section 4.10.

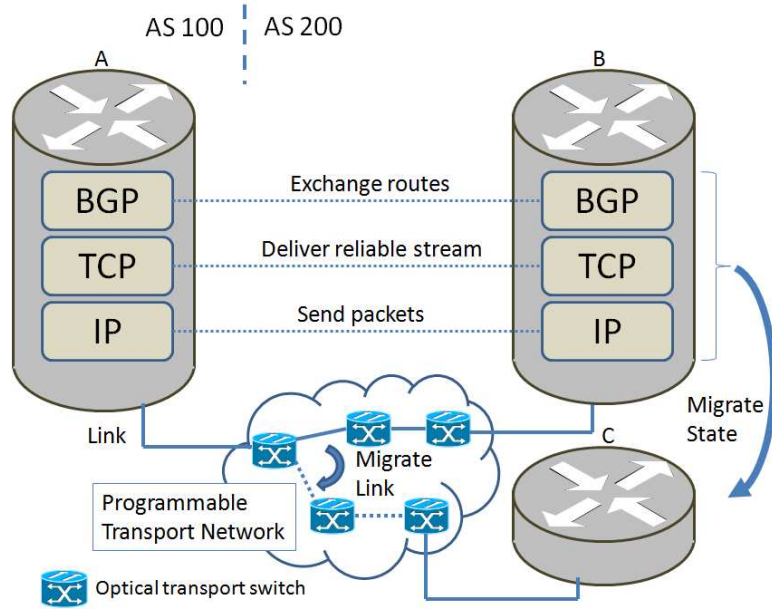

Figure 4.1: Migration protocol layers.

## 4.2 BGP Routing Within a Single AS

Grafting a BGP session is difficult because BGP routing relies on many *layers* in the protocol stack and many *components* within an AS. In this section, we present a brief overview of BGP routing from the perspective of a single autonomous system (AS) to identify the challenges our grafting solution must address.

### 4.2.1 Protocol Layers: IP, TCP, & BGP

As illustrated in Figure 4.1, two neighboring routers exchange BGP update messages over a BGP session that runs on top of a TCP connection that, in turn, directs packets over the underlying IP link(s) between them. As such, grafting a BGP session will require moving the IP link, TCP connection, and BGP session from one location to another.

**IP link:** An AS connects to neighboring ASes through IP links. While a link could be a direct cable between two routers, these IP-layer links typically correspond to multiple hops in an underlying layer-two network. For example, routers at an

exchange point often connect via a shared switch, and an ISP typically connects to its customers over an access network. These layer-two networks are increasingly programmable, allowing dynamic set-up and tear-down of layer-three links [104, 34, 14, 90]. This is illustrated in Figure 4.1 where the link between routers A and B is through a programmable transport network which can be changed to connect routers A and C. These innovations enable seamless migration of an IP link from one location to another within the scope of the layer-two network, such as rehoming a customer’s access link to terminate on a different router in the ISP’s network<sup>1</sup>.

**TCP connection:** The neighboring routers exchange BGP messages over an underlying TCP connection. Unlike a conventional TCP connection between a Web client and a Web server, the connection must stay “up” for long periods of time, as the two routers are continuously exchanging messages. Further, each router sends keep-alive messages to enable the other router to detect lapses in connectivity. Upon missing three keep-alive messages, a router declares the other router as dead and discards all BGP routes learned from that neighbor. As such, grafting a BGP session requires timely migration of the underlying TCP connection.

**BGP session:** Two adjacent routers form a BGP session by first establishing a TCP session, then sending messages negotiating the properties of the BGP session, then exchanging the “best route” for each destination prefix. This process is controlled by a state machine that specifies what messages to exchange and how to handle them. Once the BGP session is established, the two routers send incremental update messages—announcing new routes and withdrawing routes that are no longer available. A router stores the BGP routes learned from its neighbor in an *Adj-RIB-in* table, and the routes announced to the neighbor in an *Adj-RIB-out* table. Each BGP session has configuration state that controls how a router filters and modifies BGP

---

<sup>1</sup>Depending on the technology used to realize the layer-two network, the scope might be geographically contained, e.g., in the case of a packet access network, or might be significantly more spread out, e.g., in the case of a national footprint programmable optical transport network.

routes that it imports from (or exports to) the remote neighbor. As such, grafting a BGP session requires transferring a large amount of RIB (Routing Information Base) state, as well as moving the associated configuration state.

### 4.2.2 Components: Blades, Routers, & ASes

A BGP session is associated with a routing process that runs on a processor blade within one of the routers in a larger AS. As such, grafting a BGP session involves extracting the necessary state from the routing process, transferring that state to another location, and changing the routing decisions at other routers as needed.

**Processor blade:** The simplest router has a processor for running the routing process, multiple interfaces for terminating links, and a switching fabric for directing packets from one interface to another. The BGP routing process maintains sessions with multiple neighbors and runs a decision process over the *Adj-RIB-in* tables to select a single “best” route for each destination prefix. The routing process stores the best route in a *Loc-RIB* table, and applies export policies to construct the *Adj-RIB-out* tables and send the corresponding update messages to each neighbor.

**IP router:** Today’s high-end routers are large distributed systems, consisting of hundreds of interfaces and multiple processor blades spread over one or more chassis. These routers run multiple BGP processes—one on each processor blade—each responsible for a portion of the BGP sessions as shown in Figure 4.2. For a cluster-based router to scale, each BGP process runs its own decision process and exchanges its “best” route with the other BGP processes in the router, using a modified version of internal BGP (iBGP) [95]. This allows the distributed router to behave the same way as a simple router that runs a single BGP process. Any BGP process can handle any BGP session, since all processors can reach the interface cards through the switching fabric. As such, grafting a BGP session from one blade to another in

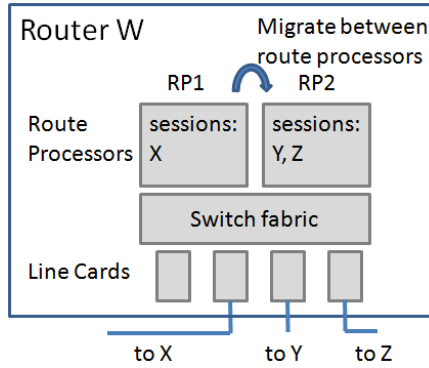

Figure 4.2: Migrating the session with X between route processor blades (from RP1 to RP2).

the same router (e.g., the session with X from RP1 to RP2 in Figure 4.2) does not require migrating the underlying layer-three link.

**Autonomous System (AS):** An AS consists of multiple, geographically-distributed routers. Each router forms BGP sessions with neighboring routers in other ASes, and uses iBGP to disseminate its “best” route to other routers within the AS. The routers in the same AS also run an Interior Gateway Protocol (IGP), such as OSPF or IS-IS to compute paths to reach each other. Each router in the AS runs its own BGP process(es) and selects its own best route for each prefix. The routers may come to different decisions about the best route, not only because they learn different candidate routes but also because the decision depends on the IGP distances to other routers (in a practice known as hot-potato routing). This can be seen in Figure 4.3 where routers B and C have different paths to the destination  $d$ . As such, grafting a BGP session from one router to another (e.g., the session with A from router B to C in Figure 4.3) may change the BGP routing decisions.

### 4.3 Router Grafting Architecture

Seamless grafting of a BGP session relies on a careful progression through a number of coordinated steps. These steps are summarized in Figure 4.4, which shows a

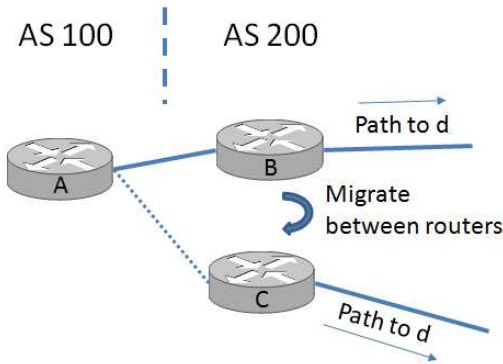

Figure 4.3: Migrating session with A between routers (from B to C).

*migrate-from* router that hands off one of its BGP sessions to a *migrate-to* router in the same AS. These routers do not need to run the same software or be from the same vendor—they need only have the added support for router grafting. When the grafting process starts, the *migrate-from* router is responsible for handling a BGP session with the remote end-point router *A* (not shown). This BGP session with router *A* is to be migrated. The *migrate-from* router begins exporting the routing information and the *migrate-to* router is initialized with its own session-level data structures and a copy of the policy configuration, without actually establishing the session (Figure 4.4(a)). Then, the TCP connection is migrated, followed by the underlying link (Figure 4.4(b)). Finally, the *migrate-to* router imports the routing state and updates the other routers (Figure 4.4(c)), resulting in the *migrate-to* router handling the BGP session with the remote end-point ((Figure 4.4(d)). This section focuses exclusively on control-plane operations, deferring discussion of the data plane until Section 4.4.

### 4.3.1 Copying BGP Session Configuration

Each BGP session end-point has a variety of configuration state needed to establish the session with the remote end-point (with a given IP address and AS number) and apply policies for filtering and modifying route announcements. The network

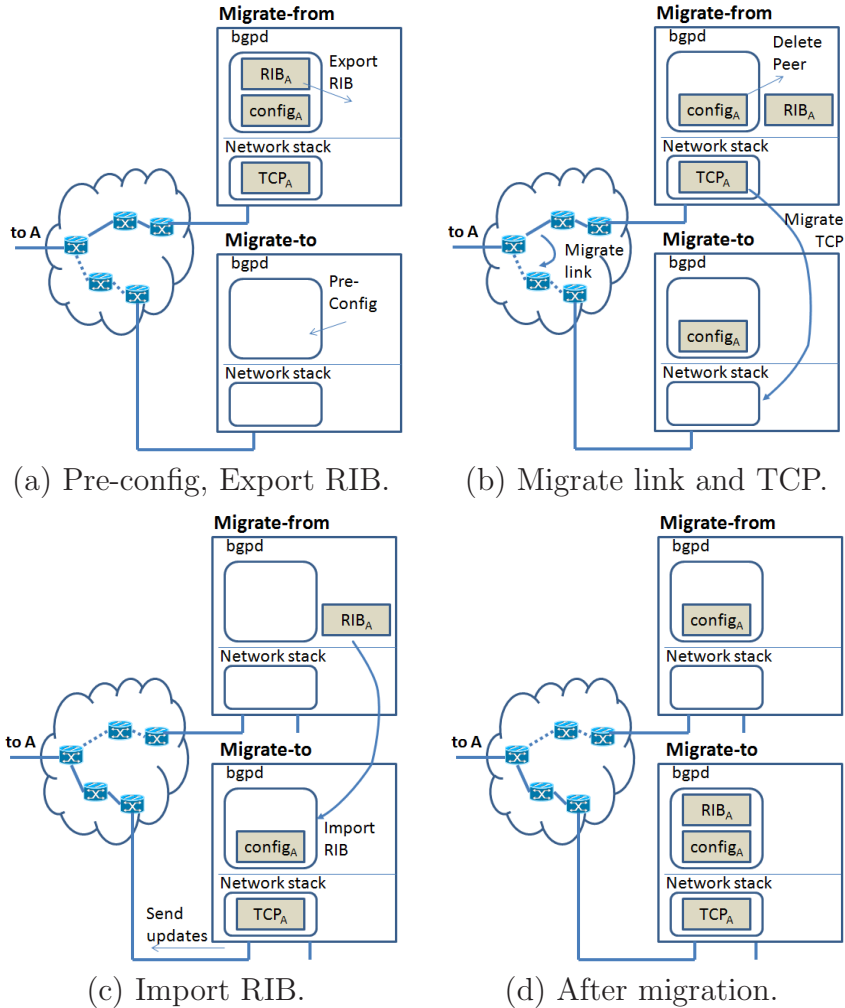

Figure 4.4: Router grafting mechanisms – migrating a session with Router A (not shown) from router Migrate-from to router Migrate-to. The boxes marked **bgpd** and **network stack** are the software programs. The boxes marked  $RIB_A$ ,  $config_A$ , and  $TCP_A$  are the routing, configuration, and TCP state respectively.

operators, or an automated management system, configure the session end-point by applying configuration commands at the router’s command-line interface or uploading a new configuration file. The router stores the configuration information in various internal data structures.

Rather than exporting these internal data structures, we capitalize on the fact that the current configuration is captured in a well-defined format in the configuration file. Our design simply “dumps” the configuration file for the migrate-from router, extracts the commands relevant to the BGP session end-point, and applies these commands to

the migrate-to router, after appropriate translation to account for vendor-dependent differences in the command syntax. This allows the migrate-to router to create its own internal data structures for the configuration information.

However, the migrate-to router is not yet ready to assume responsibility for the BGP session. To finish initializing the migrate-to router, we extend the BGP state machine to include an ‘inactive’ state, where the router can create data structures and import state for the session without attempting to communicate with the remote end-point. The migrate-to router transitions from the ‘inactive’ state to ‘established’ state when instructed by the grafting process.

### 4.3.2 Exporting & Resetting Run-Time State

A router maintains a variety of state for BGP session end-points. To meet our goals, BGP grafting need only consider the Routing Information Bases (RIBs)—the other state may be simply reinitialized at the migrate-to router<sup>2</sup>.

**Routing Information Bases (RIBs):** The most important state associated with the BGP session-end-point is stored in the routing information bases—the *Adj-RIB-in* and *Adj-RIB-out*. In our architecture, we dump the RIBs at the migrate-from router to prepare for importing the information at the migrate-to router. While the RIBs are represented differently on different router platforms, the information they store is standardized as part of the BGP protocol. In most router implementations, the RIB data structure is factored apart from the rest of the routing software, and many routers support commands for “dumping” the current RIBs. Even though the RIB dump formats vary by vendor, de facto standards like the popular MRT format [10] do exist.

---

<sup>2</sup>Router grafting does not preclude the remaining state from being included, simply we chose not to in order to keep code modifications at a minimum while still meeting our goals of (i) routing protocol adjacencies staying up and (ii) all routing protocol messages being received.

**State in the BGP state machine:** A BGP session end-point stores information about the BGP state machine. We can forgo migrating this state – the BGP session is either ‘established’ or not. If the session is in one of the not-established states, we can simply close the session at the migrate-from router and start the migrate-to router in the idle state. This does not trigger any transient disruption—since the session is not “up” anyway. If the session at the migrate-from router is ‘established,’ we can start the new session at the migrate-to router in the ‘inactive’ state.

**BGP timers:** BGP implementations also include a variety of timers, many of which are vendor-dependent. For example, some routers use an MRAI (Minimum Route Advertisement Interval) timer to pace the transmission of BGP update messages. This is purely a local operation at one end-point of the session, not requiring any agreement with the remote end-point. Another common timer is the keep-alive interval that drives the periodic sending of heartbeat messages, and a hold timer for detecting missing keep-alive messages from the remote end-point. Fortunately, missing a single keep-alive message, or sending the message slightly early or late, would not erroneously detect a session failure because routers typically wait for *three* missed keep-alive messages before tearing down the session. As such, we do not migrate BGP timer values and instead simply initialize whatever timers are used at the migrate-to router.

**BGP statistics:** BGP implementations maintain numerous statistics about each session and even individual routes. These statistics, while broadly useful for network monitoring, are not essential to the correct operation of the router. They only have meaning at the local session end-point. In addition, these statistics are vendor dependent and not well modularized in the router software implementations. As such, we do not migrate these statistics and instead allow the migrate-to router to initialize its own statistics as if it were establishing a new session.

### 4.3.3 Migrating TCP Connection & IP Link

As part of BGP session grafting, the TCP connection must move from the migrate-from router to the migrate-to router. Because we do not assume any support from the remote end-point, the migrate-to router must use the same IP addresses and sequence and acknowledgment numbers that the migrate-from router was using. In BGP, IP addresses are used to uniquely identify the BGP session end-points and not the router as a whole. Further, we assume the link between the remote end-point and the migrate-from (or migrate-to) router is a single hop IP network where the IP address is not used for reachability, but only for identification. As such, the session end-point can easily retain its address (and sequence and acknowledgment numbers) when it moves. That is, the single IP address identifying the migrating session can be disassociated from the migrate-from router and associated with the migrate-to router. Our architecture simply migrates the local state associated with the TCP connection from one router to another.

As with any TCP migration technique, the network must endure a brief period of time when neither router is responsible for the TCP connection. TCP has its own retransmission mechanism that ensures that the remote end-point retransmits any unacknowledged data. As long as the transient outage is short, the TCP connection (and, hence, the BGP session) remains up. TCP implementations tolerate a period of at least 100 seconds [24] without receiving an acknowledgment—significantly longer than the migration times we anticipate. The amount of TCP state is relatively small, and the two routers are close to one another, leading to extremely fast TCP migration times.

The underlying link should be migrated (e.g., by changing the path in the underlying programmable transport network) close to the same time as the TCP connection state, to minimize the transient disruption in connectivity. Still, the network may need to tolerate a brief period of inconsistency where (say) the TCP connection

state has moved to the migrate-to router while the traffic still flows via the migrate-from router. During this period, we need to prevent the migrate-from router from erroneously responding to TCP packets with a TCP RST packet that resets the connection. This is easily prevented by configuring the migrate-from router's interface to drop TCP packets sent to the BGP port (i.e., 179). The migrate-from route *can* successfully deliver regular *data* traffic received during the transmission, as discussed later in Section 4.4.

#### 4.3.4 Importing BGP Routing State

Once link and connection migration are complete, the migrate-to router can move its end-point of the BGP session from the 'inactive' state to the 'established' state. At this time, the migrate-to router can begin "importing" the RIBs received from the migrate-from router. However, the import process is not as simple as merely loading the RIB entries into its own internal data structures. The migrate-from and migrate-to routers could easily have a different view of the "best" route for each destination prefix, as illustrated in Figure 4.5. In this scenario, before the migration, A reaches E's prefixes over the direct link between them, and B reaches E's prefixes via A; after the migration, A should reach E's prefixes via B, and B should reach E's prefixes over the direct link. Similarly, suppose routers C and D connect to a common prefix. Before the migration, E follows the AS path "100 200 300" (through C) to reach that prefix; after the migration E follows the AS path "100 200 400" (through D). Reaching these conclusions requires routers A and B to rerun the BGP decision process based on the new routes, and disseminate any routing changes to neighboring routers.

To make the process transparent to the remote end-point, we essentially emulate starting up a new session at router B, with router A temporarily playing the role of the remote end-point to announce the routes learned from E. This requires router A to replay the Adj-RIB-in state associated with E to router B. Router B stores these

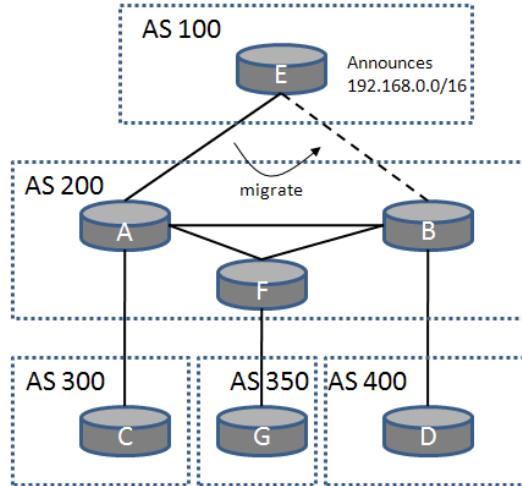

Figure 4.5: A topology where AS 200 has migrate-from router A, migrate-to router B, internal router F, and external routers C, D, and G, and remote end-point E.

routes and reruns its BGP decision process, as necessary, to compute the new best routes to prefixes E is announcing. This will cause update messages to be sent to other routers within the AS and, sometimes, to external routers (like C and D). If the attributes of the route (e.g., the AS-PATH) do not change, as is the case in Figure 4.5, other ASes like AS 300 and AS 400 do not receive *any* BGP update message (since, from their point of view, the route has not changed), thus minimizing the overhead that router grafting imposes on the global BGP routing system.

Next, we update E with the best routes selected by B. Here, we take advantage of the fact that E has already learned routes from the migrate-from router A. The change in topology might change some of those routes, and we need to account for that. To do so, the migrate-to router runs the BGP decision process to compare its currently-selected best route to the route learned from the migrate-from router. If the best route changes, B sends an update message to its neighbors, including router E. This is in fact exactly the same operation the router would perform upon receiving a route update from any of its neighbors. We expect that routers A and B would typically have the same best route for most prefixes, especially if A and B are relatively close to each other in the IGP topology. As such, most of the time router B

would not change its best route and hence would not need to send an update message to router E.

## 4.4 Correct Routing and Forwarding

Router grafting cannot be allowed to compromise the correct functioning of the network. In this section, we discuss how grafting preserves correct routing state (in the control plane) and correct packet forwarding (in the data plane), even when unexpected routing changes occur in the middle of the grafting process.

### 4.4.1 Control Plane: BGP Routing State

Routing changes can, and do, happen at any time. BGP routers easily receive millions of update messages a day, and these could arrive at any time during the grafting process – while the migrate-from router dumps its routing state, while the TCP connection and underlying link are migrated, or while the migrate-to router imports the routing state and updates its routing decisions. Our grafting solution can correctly handle BGP messages sent at any of these times.

**While the migrate-from router dumps the BGP routing state:** The goal is to have the in-memory Routing Information Base (RIB) be consistent with the RIB that was dumped as part of migration. Here, we take advantage of the fact that the dumping process and the BGP protocol work on a per-prefix basis. Consider a Adj-RIB-in with three routes (p1, p2, p3) corresponding to three prefixes, of which (p1 and p2) have been dumped already. When an update p3' (for the same prefix as p3) is received, the in-memory RIB can be updated since it corresponds to a prefix that has not been dumped, – to prevent dumping a prefix while it is being updated, the single entry in the RIB needs to be locked. If we receive an update p1' (for the same prefix as p1), processing it and updating the in-memory RIB without updating the dumped

image will cause the two to be inconsistent – delaying processing the update is an option, but that would delay convergence as well. To solve this, we capitalize on BGP being an incremental protocol where any new update message implicitly withdraws the old one. Since we treat the dumped RIB as a sequence of update messages, we can process the update immediately and append p1' to the end of the dumped RIB to keep it consistent.

**While the TCP connection and link are migrating:** BGP update messages may be sent while the TCP connection and the underlying link are migrating. If a message is sent by the remote end-point, the message is not delivered and is correctly retransmitted after the link and TCP connection come up at the migrate-to router. If an update message is sent by another router to the migrate-from router over a different BGP session, there is not a problem because the migrate-from router is no longer responsible for the recently-rehomed BGP session. Therefore, the migrate-from router can safely continue to receive, select, and send routes. If an update message is sent by another router to the migrate-to router over a different BGP session, the migrate-to router can install the route in its Adj-RIB-in for that session and, if needed, update its selection of the best route – similar to when a route is received before the migration process.

**While the migrate-to router imports the routing state:** The final case to consider is when the migrate-to router receives a BGP update message while importing the routing state for the rehomed session. Whether from the remote end-point or another router, if the route is for a prefix that was already imported, there is no problem since the migration of that prefix is complete. If it is for a prefix that has not already been imported, only messages from the remote end-point router need special care. (BGP is an asynchronous protocol that does not depend on the relative order of processing for messages learned from different neighbors.) A message from the remote end-point must be processed after the imported route but we would like to process

it immediately. Since the update implicitly withdraws the previous announcement (which is in the dump image), we mark the RIB entry to indicate that it is more recent than the dump image. This way, we can skip importing any entries in the dump image which have a more recent RIB update.

#### 4.4.2 Data Plane: Packet Forwarding

Thus far, this paper has focused on the operation of the BGP control plane. However, the control plane’s only real purpose is to select paths for forwarding data packets. Fortunately, grafting has relatively little data-plane impact. When moving a BGP session between blades in the same router, the underlying link does not move and the “best” routes do not change. As such, the forwarding table does not change, and data packets travel as they did before grafting took place – the data traffic continues to flow uninterrupted.

The situation is more challenging when grafting a BGP session from one router to another, where these two routers do not have the same BGP routing information and do not necessarily make the same decisions. Because the TCP connection and link are migrated *before* the migrate-to router imports the routing state, the remote end-point briefly forwards packets through the migrate-*to* router based on BGP routes learned from the migrate-*from* router. Since BGP route dissemination within the AS (typically implemented using iBGP) ensures that each router learns at least one route for each destination prefix, the two routers will learn routes for the same set of destinations. Therefore, the undesirable situation where the remote end-point forwards packets that the migrate-to router cannot handle will not occur.

Although data packets are forwarded correctly, the end-to-end forwarding path may temporarily differ from the control-plane messages. For example, in Figure 4.5, data packets sent by E will start traversing the path through AS 400, while E’s control plane still thinks the AS path goes through AS 300. These kinds of temporary

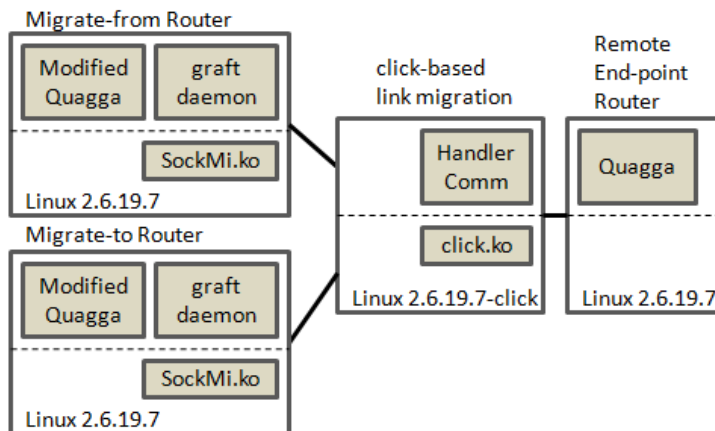

Figure 4.6: The router grafting prototype system.

inconsistencies are a normal occurrence during the BGP route-convergence process, and do not disrupt the flow of traffic. Once the migrate-to router finishes importing the routes, the remote end-point will learn the new best route and control- and data-plane paths will agree again.

Correct handling of data traffic must also consider the packets routed *toward* the remote end-point. During the grafting process, routers throughout the AS forward these packets to the migrate-from router until they learn about the routing change (i.e., the new egress point for reaching these destinations). Since the migrate-from router knows where the link, TCP connection, and BGP session have moved, it can direct packets in flight there through temporary tunnels established between the migrate-from router and the migrate-to router.

## 4.5 BGP Grafting Prototype

We have developed an initial prototype to demonstrate router grafting. Figure 4.6 depicts the main components of the prototype. These include (i) a modified Quagga [6] routing software, (ii) the graft daemon for controlling the entire process, (iii) the SockMi [21] kernel module for TCP migration, and (iv) a Click [72] based data plane for implementing link migration.

The controlling entity in the prototype is the graft daemon. This is the entity that initiates the BGP session grafting, interacting with each of the other components to perform the necessary steps. We assume each graft daemon can be reached by an IP address. With this, the graft daemon on the migrate-from router will initiate a TCP connection with the daemon on the migrate-to router. Once established, the migration process follows the six general steps discussed in the following subsections.

### 4.5.1 Configuring the Migrate-To Router

In our architecture, configuration state is gleaned from a dump of the migrate-from router's configuration file, rather than its internal data structures. The graft daemon first extracts BGP session configuration from the configuration file of the migrate-from router, including the rules for filtering and modifying route announcements. Then the extracted configuration commands are applied to the migrate-to router. Our current implementation includes a simplistic parser for Quagga's commands for configuring BGP sessions<sup>3</sup>. In order to configure the migrate-to router before migrating the TCP connection, we added an 'inactive' state to the BGP state machine. We also added a configuration command to the Quagga command-line interface:

```
neighbor w.x.y.z inactive
```

that triggers the router to create all internal data structures for the session, without attempting to open or accept a socket with the remote end-point.

### 4.5.2 Exporting Migrate-From BGP State

Once the migrate-to router is configured, the grafting process can proceed to the second step, which is initiating the export of the routing state on the migrate-from

---

<sup>3</sup>As we add support for XORP, we will develop a more complete parser as the configuration will require translating between configuration languages—generally a hard problem, though easier in our case because we focus on a relatively narrow aspect of the configuration.

router. The grafting daemon on the migrate-from router initiates the export process by calling a command in Quagga that we added:

```
neighbor w.x.y.z migrate out
```

When this command is executed, our modified Quagga software traverses the internal data structures, dumping the necessary routing state (Adj-RIB-in and the selected routes in the loc-RIB) to a file.

### 4.5.3 Exporting Migrate-From TCP State

Once the routing state is dumped, the modified Quagga calls the `export_socket` function as part of the SockMi API to migrate the TCP state. This function makes an `ioctl` call to the kernel module, passing the socket's file descriptor. The SockMi kernel module is a Linux kernel module for kernels 2.4 through 2.6—we tested with kernel version 2.6.19.7. The `ioctl` call causes the kernel module to interact with Linux's internal data structures. It removes the TCP connection from the kernel, writing the socket state to a character device. Note that part of this state is related to the protocol itself (e.g., the current sequence number) as well as the buffers (e.g., the receive queue and the transmit queue of packets sent, but not acknowledged). When this state is written, the kernel module sends a signal to the graft daemon on the migrate-from router, which can read from the character device and send to the daemon on the migrate-to router.

### 4.5.4 Importing the TCP State

The next step is to initiate the import of the TCP state at the migrate-to router. Upon receiving the state from the migrate-from router, the graft daemon on the migrate-to router first notifies Quagga that it is about to import state for a given 'inactive' session. This is done through a command we added:

```
neighbor w.x.y.z migrate in
```

Upon executing the command, our modified Quagga invokes the `import_socket` function in the SockMi API. This function blocks until a TCP connection is imported. During this time, the graft daemon makes an `ioctl` to the SockMi kernel module. The graft daemon then passes the TCP session state to a character device which is read by the kernel module. The SockMi kernel module accesses the Linux data structures to add a socket with that TCP connection state, which unblocks the `import_socket` function.

#### 4.5.5 Migrating the Layer-Three Link

At this point, the graft daemon of the migrate-to router triggers the migration of the underlying link. This includes removing the migrating session's IP address from the migrate-from router, adding the IP address to the migrate-to router, and migrating the layer-two link. As we did not have access to equipment to use a programmable transport network, we instead built our own simple layer-two network that connects both the migrate-from and migrate-to router to the remote end-point with a Click [\[72\]](#) configuration that emulates a 'programmable transport'. This Click configuration performs a simple switching primitive that connects the remote end-point to either the migrate-from or the migrate-to router. In one setting, packets from the migrate-from router are sent to the remote end-point router, packets from the migrate-to router are dropped, and packets from the remote end-point router are sent to the migrate-from router. With the alternative setting, the reverse occurs, forming a link between the migrate-to router and the remote-end point router. This switch value is settable via a handler, making it accessible to the graft daemon running on the migrate-from router.

### 4.5.6 Importing Routing State

As the final step, when the importing of the TCP connection is complete and the `import_socket` function is unblocked, the modified Quagga reads the routing state, which was stored in a file when the local graft daemon read it in from the graft daemon running on the migrate-from router. Much as the “normal” operation of the router, which receives a BGP message from a socket and then calls a function to handle the update, the importing process will read the Adj-RIB-in from a file and call the same function to process the routing update. For comparing the RIB from the migrate-from router to the migrate-to router, the importing process reads the route from the file, looks up the route in the local RIB, and compares them. If they differ, it will use existing functions to send out the route to the peer.

## 4.6 Optimizations for Reducing Impact

Grafting a BGP session requires incrementally updating the remote end-point as well as the other routers in the AS. In this section, we present optimizations that can further reduce the traffic and processing load imposed on routers not directly involved in the grafting process. These optimizations capitalize on the knowledge that grafting is taking place and the routers’ local copy of the routes previously learned from the remote end-point. First, we discuss how we can keep routers from sending unnecessary updates to their eBGP neighbors. Second, we then discuss how the majority of iBGP messages can be eliminated. Finally, we consider the intra-cluster router case where the routes do not change.

### 4.6.1 Reducing Impact on eBGP Sessions

Importing routes on the migrate-to router, and withdrawing routes on the migrate-from router, may trigger a flurry of update messages to other BGP neighbors. Con-

sider the example in Figure 4.5, where before grafting router E had announced 192.168.0.0/16 to router A, which in turn announced the route to B and C. Eventually two things will happen: (i) the migrate-from router A will *remove* the 192.168.0.0/16 route from E and (ii) the migrate-to router B will *add* the 192.168.0.0/16 route from E. Without any special coordination, these two events could happen in either order.

If A removes the route before B imports it, then A’s eBGP neighbors (like router C) may receive a withdrawal message, or briefly learn a different best route (should A have other candidate routes), only to have A reannounce the route upon (re)learning it from B. Alternatively, if B adds the route before A sends the withdrawal message to C, then A may have both a withdrawal message and the subsequent (re)announcement queued to send to router C, perhaps leading to redundant BGP messages. In the first case, C may temporarily have no route at all, and in the second case C may receive redundant messages. In both cases these effects are temporary, but we would like to avoid them if possible.

To do so, rather than deleting the route, A can mark the route as “exported”—safe in the knowledge that, if this route should remain the best route, A will soon (re)learn it from the migrate-to router B. For example, suppose the route from E is the *only* route for the destination prefix—then A would certainly (re)learn the route from B, and could forgo withdrawing and reannouncing the route to its other neighbors. Of course, if A does not receive the announcement (either after some period of time or implicitly through receiving an update with a different route for that prefix), then it can proceed with deleting the exported route.

So far we only considered the eBGP messages the migrate-from router would send. A similar situation can occur on the eBGP sessions of the other routers in the AS (e.g., router F). This is because these other routers must be notified (via iBGP) to no longer go through A for the routes learned over the migrating session (i.e., with E). Therefore, the migrate-from router must send out withdrawal messages to its iBGP neighbors

and the migrate-to router must send out announcements to its iBGP neighbors. This may result in the other routers in the AS (e.g., router F) temporarily withdrawing a route, temporarily sending a different best route, or sending a redundant update to their eBGP neighbors. Because of this, we have the migrate-from router send the marked list to each of its iBGP neighbors and a notification that these all migrated to the migrate-to router – this list is simply the list of prefixes, not the associated attributes. We expect this list to be relatively small in terms of total bytes. With this list, the other routers in the AS can perform the same procedure, and eliminate any unnecessary external messages.

#### **4.6.2 Reducing Impact on iBGP Sessions**

While using iBGP unmodified is sufficient for dealing with the change in topology brought about by migration, it is still desirable to reduce the impact migration has on the iBGP sessions. Here, since the route-selection policy will likely be consistent throughout an ISP's network, we can reduce the number of update messages sent by extending iBGP (an easier task than modifying eBGP). When the migrate-from and migrate-to routers select the same routes, the act of migration will not change the decision. Since all routers are informed of the migration, the iBGP updates can be suppressed (the migrate-from router withdrawing the route and the migrate-to router announcing the route). When the migrate-from and migrate-to routers select different routes, it is most likely due to differences in IGP distances. For the migrate-to router, the act of migration will cause all routes learned from the remote end-point router to become directly learned routes, as opposed to some distance away, and therefore the migrate-to router will now prefer those routes (except when the migrate-to router's currently selected route is also directly learned). This change in route selection causes the migrate-to router to send updates to its iBGP neighbors notifying them of the change. However, since it is more common to change routes, we can reduce the number

of updates that need to be sent with a modification to iBGP where updates are sent when the migrate-to router keeps a route instead of when it changes a route. Other routers will be notified of the migration and will assume the routes being migrated will be selected unless told otherwise.

### **4.6.3 Eliminating Processing Entirely**

Re-running the route-selection processes is essential as migration can change the topology, and therefore change the best route. When migrating within a cluster router, the topology does not change, and therefore we should be able to eliminate processing entirely. The selected best route will be a consistent selection on every blade. Therefore, even when migrating, while the internal data structures might need to be adjusted, no decision process needs to be run and no external messages need to be sent. In fact, there is no need for any internal messages to be sent either. With the modified iBGP used for communication between route processor blades, the next hop field is the next router, not the next processor blade – i.e., iBGP messages are only used to exchange routes learned externally and do not affect how packets are forwarded internally. Therefore, upon migration, there is no need to send an update as the routes learned externally have already been exchanged.

While exchanging messages and running the decision process can be eliminated, transferring the routing state from the exporting blade to the importing blade is still needed. Being the blade responsible for a particular BGP session requires that the local RIB have all of the routes learned over that session. While some may have been previously announced by the migrate-from blade, not all of them were. Therefore, we need to send over the Adj-RIB-in for the migrating session in order to know all routes learned over that session as well as which subset of routes the migrate-from blade announced were associated with that session.

## 4.7 Performance Evaluation

In this section, we evaluate router grafting through experiments with our prototype system and realistic traces of BGP update messages. We focus primarily on control-plane overhead, since data-plane performance depends primarily on the latency for link migration—where our solution simply leverages recent innovations in programmable transport networks. First, we evaluate our prototype implementation from Section 4.5 to measure the grafting time and CPU utilization on the migrate-from and migrate-to routers. Then we evaluate the effectiveness of our optimizations from Section 4.6 in reducing the number of update messages received by other routers.

### 4.7.1 Grafting Delay and Overhead

The first experiment measures the impact of BGP session grafting on the migrate-from and migrate-to routers. To do this we supplemented the topology shown in Figure 4.5 with a router adjacent to E (in a different AS) and a router adjacent to B (in a different AS). These two extra routers were fed a BGP update message trace taken from RouteViews [7]. This essentially fills the RIB of B and E with routes that have the same set of prefixes, but different paths. We used Emulab [105] to run the experiment on servers with 3GHz processors and 2GB RAM.<sup>4</sup>

The time it takes to complete the migration process is a function of the size of the routing table. The larger it is, the larger the state that needs to be transferred and the more routes that need to be compared. To capture this relationship, we varied the RIB size by replaying multiple traces. The results, shown in Figure 4.7, include both the case where migration occurs between routers (when the migrate-to router must run the BGP decision process) and the case where migration is between blades (where the decision process does not need to run because the underlying topology

---

<sup>4</sup>This is roughly comparable to the route processors used in commercially available high-end routers.

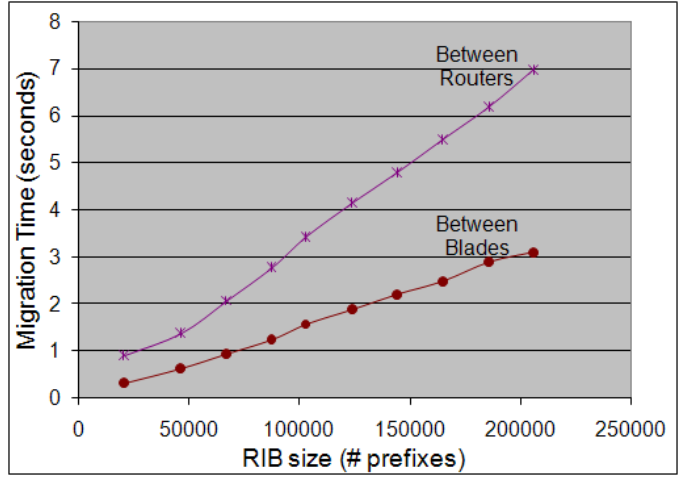

Figure 4.7: BGP session grafting time vs. RIB size.

is not changed). The “between blades” curve, then, illustrates the time required to transfer the BGP routes and import them into the internal data structures. Note that these results do not imply that TCP needs to be able to handle this long of an outage where packets go unacknowledged – the TCP migration process takes less than a millisecond. Instead, when compared to rehomeing a customer today, where there is downtime measured in minutes, the migration time is small. In fact, since in our setup AS100 and AS200 have a peering agreement, the actual migration time would be less if AS100 were a customer of AS200 (since AS100 would announce fewer routes to AS200).

The CPU utilization during the grafting process is also important. The BGP process on the migrate-from router experienced only a negligible increase in CPU utilization for dumping the BGP RIBs. The migrate-to router needs to import the routing entries and compare routing tables. For each prefix in the received routing information, the migrate-to router must perform a lookup to find the routing table entry for that prefix. Figure 4.8 shows the CPU utilization at 0.2 second intervals, as reported by *top*, for the case where the RIB consists of 200,000 prefixes. There are three things to note. First, the CPU utilization is roughly constant. This is perhaps due to the implementation where the data is received, placed in a file, then

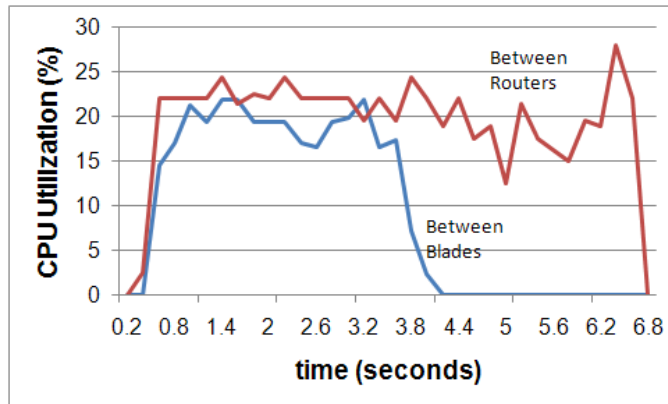

Figure 4.8: The CPU utilization at the migrate-to router during migration, with a 200k prefix RIB.

iteratively read from the file and processed before reading the next. This keeps the CPU utilization at only a fraction as computation is mixed with reads from disk. Second, the CPU utilization is the same for both migrating between routers and migrating between blades. The case between routers merely takes longer because of the additional work involved in running the BGP decision process. Third, migration can be run as a lower priority task and use less CPU but take longer – preventing the migration from effecting the performance of the router during spikes in routing updates, which commonly results in intense CPU usage during the spikes.

#### 4.7.2 Optimizations for Reducing Impact

While the impact on the migrate-from and migrate-to routers is important, perhaps a more important metric is the impact on the routers *not* involved in the migration, including other routers within the same AS as well as the eBGP neighbors. If the overhead of grafting is relatively contained, network operators could more freely apply the technique to simplify network-management tasks.

First and foremost, the remote end-point experiences an overhead directly proportional to the number of additional BGP update messages it receives. The number of messages depends on how many best routes differ between the migrate-from and

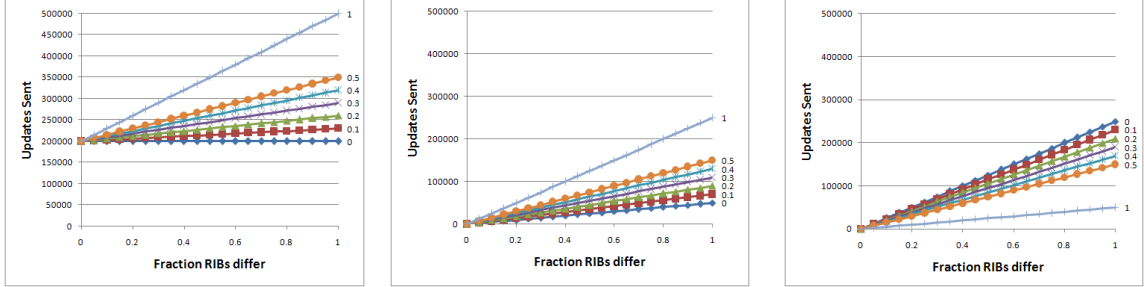

(a) Without optimization. (b) Reducing eBGP impact. (c) Reducing iBGP impact.

Figure 4.9: Updates sent as a result of migration.

migrate-to router—the migrate-from router must send an update message for every route that differs. The exact amount depends heavily on the proximity of the migrate-from and migrate-to routers—if the two routers are in the same Point-of-Presence of the ISP, perhaps no routes would change. As such, we do not expect this overhead to be significant. Since the sources of overhead for the remote end-point are relatively well understood, and it is difficult to acquire the kinds of intra-ISP measurement data necessary to quantify the number of route changes, we do not present a plot for this case.

Perhaps the more significant impact is on the other routers, both within the AS and in other ASes, that may have to learn new routes for the prefixes announced by the remote end-point. To evaluate this, we measured the number of updates that would be sent as a function of the fraction of prefixes where the migrate-from router had selected a different route than the migrate-to router. By doing so, this covers the entire range of migration targets (i.e. it does not limit our evaluation to migration within a PoP). Recall that this difference is what needs to be corrected. Also recall that the prefixes being considered here are the ones learned from the router at the remote end-point of the session being migrated, not the entire routing table, as these are the routes that could impact what is sent to other routers. For our measurement, we use a fixed set of 100,000 prefixes. However, the results are directly proportional to the number of prefixes, and can therefore be scaled appropriately – for migrating

a customer link, the number of prefixes would be significantly smaller, for migrating a peering link, the number of prefixes could be higher.

The results are shown in Figure 4.9, with the three graphs representing the three different cases as discussed in Section 4.6: (a) direct approach with no optimizations, (b) optimizations to reduce eBGP messages by capitalizing on redundant information in the network, and (c) optimizations to reduce iBGP messages by treating the route selection changing as the common case. For the graphs, each line represents a fixed fraction of differing routes that change the selected route as a result of the grafting. For example, consider where the migrate-from router selects a particular route different than the migrate-to router. In this case, after migration, the migrate-to router selects the route the migrate-from selected (i.e., it changes its own route). Each line represents the fraction of times this change occurs—for example, the line labeled 0.2 in Figure 4.9 is where 20% of the routes that differ will change to the routes selected by the migrate-from router.

There are several things of note from the graphs. First is that the direct (un-optimized) approach must send significantly more messages. In the case where the selected routes do not differ much, which we consider will be a most likely scenario, the optimized approaches hardly send any messages at all. Second, when comparing Figure 4.9(b) with Figure 4.9(c), we can see that depending on what would be considered the common case, we can choose a method that would result in the fewest updates. For (b), the assumption is that when the routes differ, the migrate-to router will not change to the routes the migrate-from selected. Whereas in (c), the assumption is that when the routes differ, the migrate-from router will change to the routes the migrate-from router selected. The reason they would change is that the routes learned from the remote end-point of the session being migrated will now be directly learned routes, rather than via iBGP. It is likely that the policy of route selection is consistent throughout the ISPs network, and therefore differences will be due to IGP

distances and changing the router will change those routes to be more preferable. We are working on characterizing when these differences would occur in order to enable us to predict the impact a given migration might have. Third, and perhaps most important, migration can be performed with minimal disruption to other routers in the likely scenario where there are few differences in routes selected.

## 4.8 Traffic Engineering with Grafting

In addition to the performance of the router grafting mechanism itself, we are also interested in applying router grafting to new application areas. Here, we evaluate router grafting for traffic engineering. To do so, we first give a brief overview of traffic engineering today. We follow this with a description of our model for migration-aware traffic engineering. Finally, we present an algorithm based on this model and evaluate with traffic data from Internet2.

### 4.8.1 Traffic Engineering Today

In traditional traffic engineering, the network is represented by a graph  $G = (V, E)$ , where the vertex set  $V$  represents routers or switches, and the edge set  $E$  represents the links. Every edge  $e \in E$  has capacity  $c_e > 0$ . We are also given a *traffic matrix*  $D = \{d_{ij}\}_{i,j \in V}$ , where entry  $d_{ij} \geq 0$  is the amount of traffic that vertex  $i$  wishes to send vertex  $j$ . The goal is to distribute flow across the paths from  $i$  to  $j$  to minimizing total link usage (TLU).

TLU minimization reflects a common goal in ISP networks [49]. Each link  $e$  has a “cost” that reflects its level of congestion, where lightly-loaded links are “cheap” and links become exponentially more “expensive” as the link becomes heavily loaded. The *cost function*  $\phi_e$  specifies the cost as a function of  $f_e$  (the total flow traversing

the edge) and  $c_e$  (the edge capacity). Every  $\phi_e$  is a piecewise linear, strictly increasing and convex function.

We use the cost function from [49], shown below:

$$\phi_e(f_e, c_e) = \begin{cases} f_e & 0 \leq \frac{f_e}{c_e} < \frac{1}{3} \\ 3f_e - \frac{2}{3}c_e & \frac{1}{3} \leq \frac{f_e}{c_e} < \frac{2}{3} \\ 10f_e - \frac{16}{3}c_e & \frac{2}{3} \leq \frac{f_e}{c_e} < \frac{9}{10} \\ 70f_e - \frac{178}{3}c_e & \frac{9}{10} \leq \frac{f_e}{c_e} < 1 \\ 500f_e - \frac{1468}{3}c_e & 1 \leq \frac{f_e}{c_e} < \frac{11}{10} \\ 5000f_e - \frac{16318}{3}c_e & \frac{11}{10} \leq \frac{f_e}{c_e} < \infty \end{cases}$$

The goal is to distribute the *entire* demand between every pair of vertices in a manner that minimizes the sum of all link costs (i.e.,  $\sum_{e \in E} \phi(f_e, c_e)$ ). (Observe that the flow along an edge can exceed the edge’s capacity.) TLU minimization can be formulated as *minimum-cost multicommodity flow* and is thus computable using existing algorithms for computing multicommodity flows. Realizing this objective in practice can be done via MPLS and a management system that solves the optimization problem and installs the resulting paths. Network operators often take the indirect approach of tuning Interior Gateway Protocol (IGP) weights to closely approximate the optimal distribution of the traffic [49].

## 4.8.2 Migration-Aware Traffic Engineering

We now extend the traffic-engineering model in Section 4.8.1 to incorporate migration. Table 4.1 summarizes the notation.

**Distinguishing users from network nodes:** In our model for traffic engineering with migration, the network (see Figure 4.10) is represented by a graph  $G = (V, E)$ , where the vertex set  $V$  is the union of two disjoint subsets,  $U$  and  $N$ .  $U$  is the set

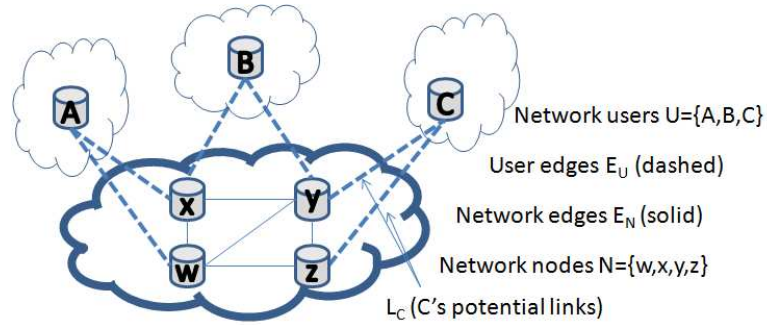

Figure 4.10: Network model for traffic engineering with migration.

Notation	Description
$G$	Network graph $G = (V, E)$
$V$	Network vertex, union of $U$ and $N$
$E$	Network edge, union of $E_U$ and $E_N$
$U$	Set of network users
$N$	Set of network nodes
$E_U$	Subset of edges that connect user $u \in U$ to network nodes in $N$ , $E_U \subseteq U \times N$
$E_N$	Subset of edges that connect network node $n \in N$ to network nodes in $N$ , $E_N \subseteq N \times N$
$c_e$	capacity of edge $e \in E$
$L_u$	Potential links, $L_u \subseteq E_U$
$D$	Demand matrix, $D = \{d_{ij}\}_{i,j \in U}$
$d_{ij}$	Amount of traffic that user $i$ wishes to send user $j$
$\phi_e$	cost function used in TLU minimization, function of $f_e/c_e$
$f_e$	Total flow traversing the edge $e$

Table 4.1: Summary of notation used in model of traffic engineering with migration.

of *network users*, that is, originators and receivers of traffic, and  $N$  is the the set of *network nodes*, that is, the routers/switches in the network. The term “users” here refers to users of the network and not to end-users. In an ISP network, the set of users  $U$  represents routers in neighboring networks (“adjacent routers”) and the set of network nodes  $N$  represents the routers in the ISP’s internal network (“internal routers”).

**User edges are potential links:** To capture the ability to migrate, we introduce the notion of *potential links* that represent the locations where the user can *possibly* connect to the network. The edge set  $E$  is the union of two disjoint subsets,  $E_U$  and  $E_N$ , where  $E_U \subseteq U \times N$  is the subset of edges connecting users to network nodes, and  $E_N \subseteq N \times N$  is the subset of edges connecting network nodes to other network nodes. Each edge  $e \in E_N$  has capacity  $c_e \geq 0$ , which measures the amount of flow that can traverse edge  $e$ . We impose no capacity constraints on the edges in  $E_U$  (that is, these edges have infinite capacity). We call the set of all edges  $L_u \subseteq E_U$  that connect user  $u \in U$  to network nodes in  $N$  “the set of  $u$ ’s *potential links*” (that is,  $\forall u \in U, L_u = \{e = (u, v) \mid e \in E_U\}$ ).

In ISP networks, the set of potential links  $L_u$  for each adjacent router (user)  $u$  represents the points at which  $u$  can connect to the ISP network. This can, in practice, depend on the underlying transport network that can, for example, limit a user to connecting only to network nodes in nearby geographical regions. In addition, the set of potential links can reflect latency considerations, *e.g.*, it is beneficial to home frequently-communicating users near each other.

**Demand matrix is user-to-user:** Our model distinguishes network users from network nodes, and our demand matrix captures this distinction; we are now given a demand matrix  $D = \{d_{ij}\}_{i,j \in U}$ , where each entry  $d_{ij}$  specifies the amount of traffic *user*  $i$  wishes to send *user*  $j$ .

**Each user must use a single potential link:** The high-level goal is, for every pair of users  $i$  and  $j$  such that  $d_{ij} > 0$ , to distribute flow from  $i$  to  $j$  between the routes from  $i$  to  $j$  in  $G$ , subject to the constraint that every user can only connect to the network via a *single* link. That is, for every user  $u \in U$ , traffic flowing from that user to the other users, and vice versa, can only traverse a single edge in  $L_u$ ; traffic along all other edges in  $L_u$  must be 0. When optimizing the flow of traffic through the network we can again consider the TLU minimization objective.

### 4.8.3 Practical Considerations

Naturally, our formal framework does not capture all the constraints that could arise in practice. We now present several such constraints and discuss how these can be incorporated into our model. We leave these as interesting directions for future research.

**Cost of migration.** Our framework does not model the cost of migration (in terms of processing, offline time, and more) yet this is expected to be a consideration in practice (we present some indication of the impact of this cost, based on experiments with Internet2 data, in Section 4.8.8). We can incorporate that cost into our model as follows. The input will include, in addition to the other components, an edge  $\bar{e}_u \in L_u$ , for every user  $u \in U$ , that represents the link that user  $u$  is *currently* using to connect to the network, and also costs associated with changing each user  $u$ 's current connection edge to other edges in  $L_u$ .

**Router limitations.** Other practical considerations are the physical limitations of the individual vertices in the network, including the number of links that each vertex can support, and also the capacity of the node (in terms of processing, memory, bandwidth, *etc.*). This can be incorporated into our model through additional constraints

(*e.g.*, limits on the number of incoming links per node, node-capacity functions dependent on incoming traffic amount, *etc.*).

**Multi-homed users.** We did not model the case that users are multi-homed, that is, that users connect to the network at more than one location. This alters our constraint that a single potential link must be chosen per user. To incorporate this into our model we can introduce a variable for each user  $u$  that specifies how many links in  $L_u$  that user is allowed to send/receive traffic along. It also adds the complexity that changing the ingress point may alter the egress point (*i.e.*, “hot-potato routing” [97]), thus changing the traffic matrix beyond the change introduced with migration. The design and evaluation of heuristics/algorithms for this more general environment is left for future work.

#### 4.8.4 The Max-Link Heuristic

Determining which edge links to migrate requires new algorithms that complement traditional traffic engineering algorithms. We present a simple heuristic, that we term the “*max-link heuristic*”, which uses a multicommodity flow solution to guide the choice of a potential link for each user (which determines which edge links need to migrate).

The max-link heuristic first computes the multicommodity flow in the input network that contains *all* potential links. Then, the heuristic uses this “fully fractional” flow (where users’ traffic can be split between all of their potential links) to choose a *single* potential link for each user, thus constructing a feasible (“integral”) solution. To do this, the max-link heuristic discards, for every user  $u \in U$ , all potential links in  $L_u$  but the single potential link which carries the most traffic in the multicommodity flow solution (breaking ties arbitrarily).

The max-link heuristic consists of these three steps:

- **Step I: Compute multicommodity flow  $f$**  in the input network  $G$  (that contains *all* potential links for each user) for the given demand matrix  $D$ . That is, compute the minimum-cost multicommodity flow for TLU minimization without restricting users to sending and receiving traffic along a single potential link. The multicommodity flow solution  $f$  tells us how much traffic every user  $u$  sends and receives along each of the potential links in  $L_u$ . We let  $t(l_u)$  denote the sum of traffic that user  $u$  sends and receives along the potential link  $l_u \in L_u$ .
- **Step II: Use the most utilized potential link.** Choose, for every user  $u \in U$ , a potential link for which  $t(l_u)$  is maximized. (Migrate users' currently connected link to the chosen potential link if necessary.)
- **Step III: Compute the multicommodity flow in the resulting network,** that is, in the network obtained through the removal from  $G$  of all potential links but those chosen above. The max-link heuristic outputs (1) the choice of a single potential link for each user and (2) the optimal routing of traffic subject to these migration decisions.

### 4.8.5 Experimental Results on Internet2

We now present our experimental evaluation of the max-link heuristic. The goal of this evaluation is to demonstrate the benefits of using migration in traffic engineering, even with a simple heuristic. We first show in Section 4.8.6 that our max-link heuristic does indeed lead to an improvement in network performance. We then examine two additional concerns relating to more practical questions – how often do links need to be migrated (Section 4.8.7) and how many links need to be migrated (Section 4.8.8).

We based all of our experiments on data collected from Internet2 [60], which consists of  $N = 9$  core routers and  $U = 205$  external routers<sup>5</sup>. We collected one week of data starting January 18, 2010. From each router, we downloaded the previously collected NetFlow data which provides summaries of the sampled flows (at the rate of 1/100 packets) in 5-minute intervals (1-week of traffic is 2016 5-minute samples). We also downloaded the routing information base (RIB) and the output for the ‘*show bgp neighbor*’ command, both of which are captured every two hours. Every NetFlow entry contains the incoming interface, which we used to represent an external source user. We used the routing tables for each of the routers to determine the egress router for each flow, along with the specific interface on the egress router that the flow exits the network on, which we used to represent the external destination user. This enabled us to generate an external-user-to-external-user traffic matrix.

#### 4.8.6 Migration Improves Network Utilization

The first metric of importance is simply the improvement that can be obtained when utilizing link migration. Our results for a single 5-minute period appears in Figure 4.14. This particular interval was chosen as it represents the average performance, which we discuss later in this subsection. The Figure shows results for the original (optimally engineered) network (the “original topology” line), and for traffic engineering with migration with 2 links per user (the “optimized topology” line)<sup>6</sup>. Our choice of the set of potential links (the  $L_u$ ’s) in the experiments was based on geographical distance, with the users’ locations inferred from which router they are connected to in the original topology – e.g., some users connected in Chicago would

---

<sup>5</sup>Determined from examining BGP information as well as traffic traces – in reality, we may have been missed an externally connected router or we may have included a router that is not externally connected.

<sup>6</sup>We do not present results for more potential links per-user, as in our small topology almost every two users end up connected to a common network node when there are many potential links, and thus traffic between these users does not traverse the network at all. To elaborate, consider the extreme case in which all users have potential links to all routers. Here, a multicommodity flow solution will give no guidance on which links to use since no traffic will even traverse the network.

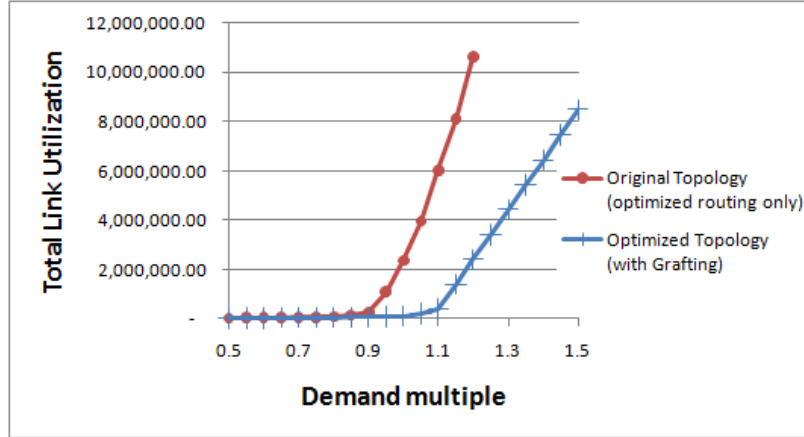

Figure 4.11: Evaluation of max-link for a single 5-minute period.

have New York as a second potential link (in addition to Chicago), others would have Kansas as a second potential link.

In the max-link heuristic, in Step I we calculate the TLU minimizing multicommodity flow of a graph which includes the potential links. The input is a prediction of what the expected demands will be so that a new topology can be optimized for it. For this experiment, we utilized the actual demand matrix, in essence giving perfect predictive power. We rely on an ISPs ability to predict traffic based on past history.

To obtain the graph in Figure 4.14, we varied the traffic demand by scaling all entries by a multiplicative factor, plotted on the x-axis, and optimized for the TLU for each. TLU minimization captures the goal of avoiding congestion, and involves an exponentially increasing cost for utilizing a link (see Section 4.8.2). We used the cost function from [49] as detailed in Section 4.8.1.

Due to the exponentially increasing cost, the network operator will wish to be at a point in the curve that comes before the exponential rise, that is, before the “knee” in the curve. Observe that this “knee” shifted to the right by roughly 20%, and so, with migration, the network can handle 20% more traffic with the same level of congestion.

As mentioned, the particular 5-minute interval was chosen as it represents the average case performance. To expand on this, we present in Figure 4.12 and Figure 4.13 the results for all 2016 5-minute intervals. In Figure 4.12, we show a time-series representation where each data point represents the improvement achieved with link migration. We define this improvement metric as the amount of traffic the network can carry in the optimized topology at the same level of congestion as the original topology – where the TLU represents the level of congestion. So, from the original topology, we found the minimal TLU with a demand multiple of 1 (e.g., the actual amount of traffic). We then determined which demand multiple in the optimized topology (i.e., with migration) would result in the same TLU. In other words, in terms of the graph in Figure 4.11, we found the y value for  $x=1$  on the original topology line, and used that y value to find the x value on the optimized topology line. Plotted in Figure 4.13 is a cumulative distribution function of the same information.

From this we can see on average, traffic engineering with migration can increase network utilization by about 18.8%. Intuitively this comes from two factors. The first is that by optimizing the homing locating based on the demand matrix, users that communicate will tend to get closer together. Without link migration, the homing location must be determined up front and then cannot change. With link migration, we can alter the topology to bring users that communicate a lot closer together. The second factor is that by re-optimizing the topology, we can have a significant impact on congested links. By giving some traffic the ability to avoid the congested link (through migration), we can reduce the congestion on that link. There are, however, a small number of cases (2.6%) where migrating links actually decreased performance. Being a simple heuristic, there are no worst case guarantees with our max-link heuristic, and so it is expected that there can be conditions which result in poor performance.

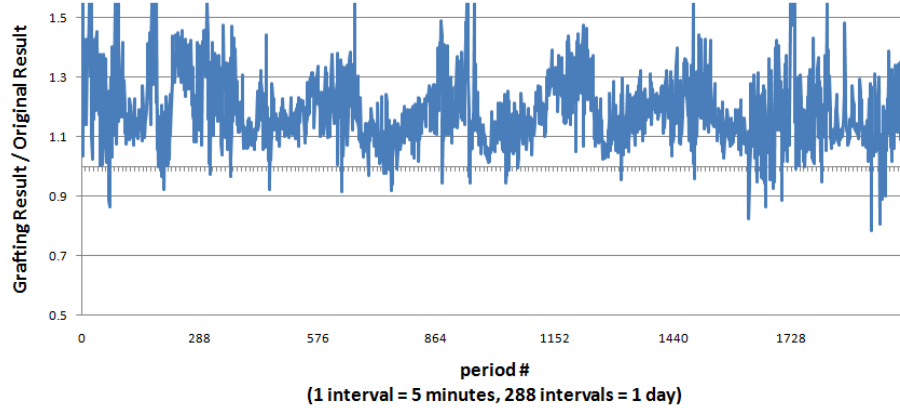

Figure 4.12: Evaluation of max-link over 7 days of traffic – time-series.

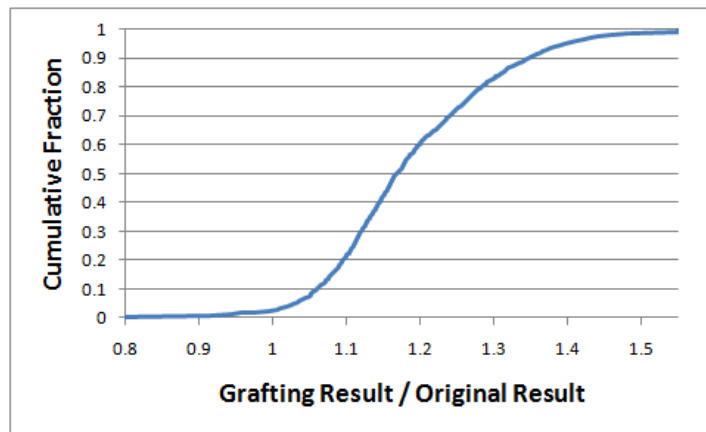

Figure 4.13: Evaluation of max-link over 7 days of traffic – cumulative distribution function.

#### 4.8.7 Frequent Migration is Not Necessary

In Section 4.8.6, we examined the benefits of utilizing link migration in traffic engineering. We looked at the benefits when we could migrate every interval and knew the traffic in the next interval. However, predicting this can be difficult on that short of a time scale. Here, we examine how frequent we really need to be migrating.

To determine how frequent migration should occur, we looked at different periods – every 5 minutes, 30 minutes, 1 hour, 6 hours, 12 hours, 24 hours. We utilized a prediction of the average demand matrix for the next interval (e.g., the next 6 hours) when computing the multicommodity flow as per Step I in the max-link heuristic. This was used to determine the optimized topology that would be used for the entire

interval	min	max	mean	#worse (frac.)
5 mins	0.783	1.55	1.188	54 (0.0267)
30 mins	0.757	1.55	1.166	146 (0.0724)
1 hour	0.777	1.55	1.163	152 (0.0753)
6 hours	0.801	1.55	1.149	182 (0.0902)
12 hours	0.856	1.55	1.141	191 (0.0947)
24 hours	0.806	1.55	1.083	465 (0.2306)

Table 4.2: Comparison of the improvement over the original topology optimized for routing only when performing grafting at different intervals (over 7 days traffic).

interval. We determined the TLU for each 5-minutes of traffic using this topology and compared the results to the original topology.

Shown in Table 4.2, are the results for the different intervals – showing the data point with the worst performance, the best performance (capped at 1.55 due to run time of the experiment), the average performance, and the number (and fraction) of data points which were worse. As could be expected, the longer the interval, the worse the results. However, even re-optimizing the topology every 6 or 12 hours still has good performance. Not only does utilizing longer intervals cut down on any overhead of the migration itself (including calculating what to migrate), but it also has the advantage that as the intervals become longer, traffic patterns smooth out and become more predictable.

#### 4.8.8 Only a Fraction of Links Need to be Migrated

Our formulation of traffic engineering with migration does not currently incorporate the cost of migration, yet this is expected to be a consideration in practice. To decide which users to migrate, we can weigh the cost of migrating a user against the gain from migrating that user; when the impact of migrating a user is low (*e.g.*, when that user generates and consumes negligible amounts of traffic), migration might be undesirable.

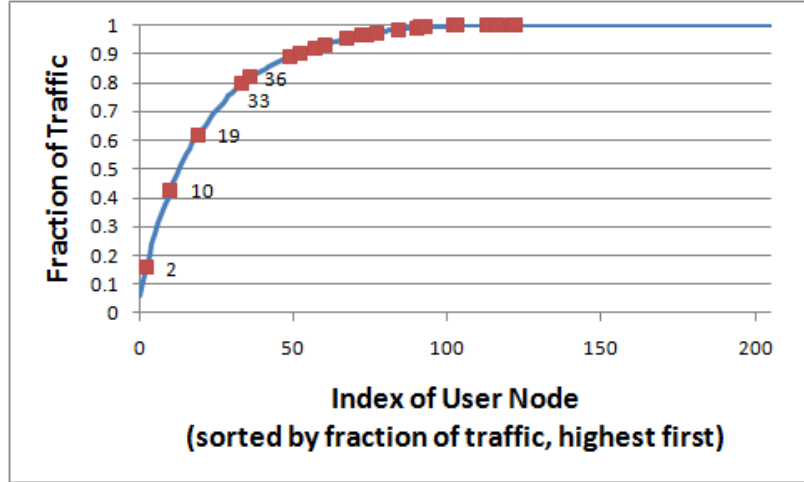

Figure 4.14: Fraction of traffic each user node sends in an example 5-minute period.

To investigate this, we plotted in Figure 4.14 the amount of traffic each user sends or receives for an example 5-minute interval. On the x-axis is the index of the user, sorted by the amount of traffic they generate/consume. On the y-axis is the cumulative fraction of the total traffic. We placed markers on each user for which our max-link heuristic determined should be migrated.

From this we can see that 85% of the traffic comes from the first 42 users, of which, max-link only determined 5 of them to be migrated. Hence, we can still obtain a significant improvement in network performance while migrating only a small number of links.

To evaluate this effect across the entire data sample, we plot the cumulative distribution functions of the number of links that need to be migrated considering three different thresholds – 100% (i.e., migrate all links that max-link determined need to be migrated), 95%, and 90%. As can be seen, by not worrying about a small fraction of traffic (which only minimally affect the actual network utilization), we can greatly reduce the number of links that need to be migrated.

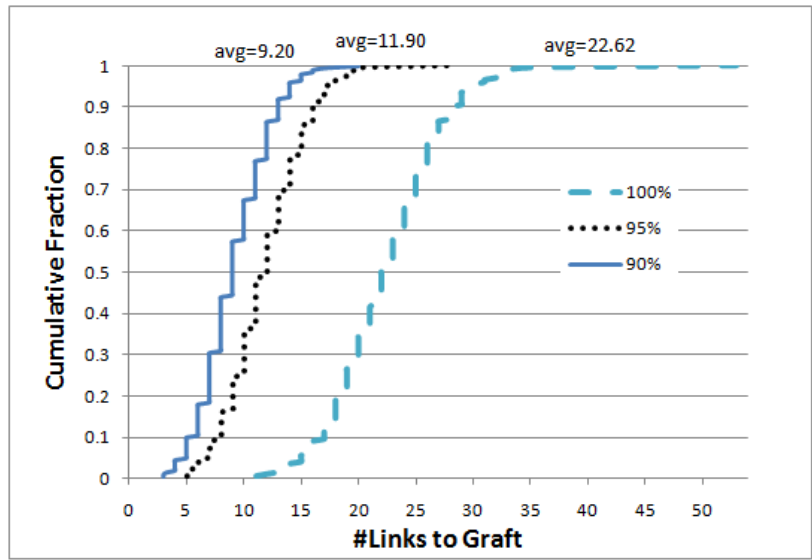

Figure 4.15: Cumulative distribution function of the number of links that need to be migrated during each interval over 7 days of traffic (2016 5-minute intervals). Shown are three lines corresponding to different thresholds – only links in the top X% of traffic are migrated.

### 4.9 Related Work

High availability and ease of network management are goals of many systems, and therefore router grafting has much in common with them. In particular, ones that attempt to minimize disruptions during planned maintenance. One possibility is to reconfigure the routing protocols such that traffic will no longer be sent to the router about to undergo maintenance [98, 52]. Alternatively, others have decoupled the control plane and data plane such that the router can continue to forward packets while the control plane goes off-line (e.g., rebooted) [93, 32]. However, unlike router grafting, these require modifications to the remote end-point router and they are only useful for temporarily shutting down the session on a given physical router, rather than enabling the session to come back up on a different router as in router grafting.

In this regard, router grafting shares more in common with VROOM (as discussed in Chapter 3), which makes use of virtual machine migration to ease network management. Maintenance could be performed without taking down the router simply

by migrating the virtual router to another physical router. This requires the two physical routers to be compatible (running the same virtualization technology), a limitation router grafting does not have. In fact, router grafting does not rely on virtual machine technology. Kozuch showed the ability to migrate without the use of virtualization [73], but did so at the granularity of the entire operating system and all running processes. With a coarse granularity, the physical router where the virtual router is being migrated to must be able to handle the entire virtual router's load.

Router grafting is also similar to the RouterFarm work [14], which targeted re-homing a customer. However, it required restarting the session and is more disruptive than router grafting. Along similar lines, high-availability routers enable switching over to a different router or blade in a router [3]. This, however, is done either through periodically check-pointing, which preserves the memory image, or running two complete instances of the router software concurrently, which is an inefficient use of resources.

While we presented router grafting in the context of a BGP session, we envision it being more general. Along these lines, partitioning the prefix space across multiple routers or blades is a possibility. ViAggre [19] partitions the prefix space across multiple routers, however it is a static architecture not one which dynamically repartitions the prefix space as router grafting could.

Finally, we made use of TCP socket migration to handle change or disruption in end-points. One alternative is to modify the TCP protocol to include the ability to change IP addresses [94]. Since the IP address of the end-points in router grafting can remain the same, we do not need this capability, but could make use of it.

In terms of our application of router grafting to traffic engineering, there has been much work on schemes for traffic engineering in ISP networks [101][63][43][18][109]. This work interprets traffic engineering as the adaptation

of the routing of traffic within the network so as to optimize performance. We, in contrast, *also* explore how to adapt traffic’s ingress and egress points.

Changes to the traffic matrix can also result from actions of the users themselves (*e.g.*, using overlay routing to route around congested areas, as in Detour [92] and RON [17]). However, such “selfish” overlay routing can, as pointed out in [82], significantly reduce the effectiveness of traffic engineering (as it lies outside the control of the ISP network operator). Interestingly, as these overlays shift the traffic, migration could be used to better handle the traffic within the ISP’s network.

Migration in the ISP context has received but little attention. Mechanisms for the re-home of customers have been introduced [14], but the implications for traffic engineering has not been studied.

## 4.10 Summary

Router grafting is a new technique that opens many new possibilities for managing a network. It does this by enabling, without disruption, the migration of a routing session between (i) physical routers, (ii) blades in a cluster router, and (iii) routers from different vendors. We were able to do this while being transparent to the remote end-point. We handled the changes in topology through incremental updates, only sending out the necessary updates to convey the difference. Importantly, we did not affect the correctness of the network as the data plane will continue to forward packets and routing updates do not cause the migration to be aborted. Through the development of new algorithms and evaluation with real traffic, we demonstrated the applicability of router grafting to traffic engineering. Not only can router grafting simplify existing network management tasks, but it can also enable new applications.

# Chapter 5

## Conclusion

The Internet is becoming a more integral part of people’s daily life – a trend that will undoubtedly continue into the future. In order to run the underlying infrastructure, network operators continuously need to make changes to the network – e.g., add routers, change policies, and manage available resources such as bandwidth. Unfortunately, these changes causes disruption. In this dissertation we take a novel approach to addressing this disruption by refactoring the router software to better accommodate change. In this chapter we present a summary of the contributions in Section 5.1. We then present a unified architecture which combines the three systems presented in this dissertation in Section 5.2. We discuss some directions for future work in Section 5.3 and wrap up with some concluding remarks in Section 5.4.

### 5.1 Summary of Contributions

This dissertation proposes a refactoring of router software in order to provide a more reliable network.

First, we tailored software and data diversity (SDD) to the unique properties of routing protocols, so as to avoid buggy behavior at run time. Our bug-tolerant router executes multiple diverse instances of routing software, and uses voting to determine

the output to publish to the forwarding table, or to advertise to neighbors. We designed and implemented a router hypervisor that makes this parallelism transparent to other routers, handles fault detection and booting of new router instances, and performs voting in the presence of routing-protocol dynamics, without needing to modify software of the diverse instances. Experiments with BGP message traces and open-source software running on our Linux-based router hypervisor demonstrated that our solution scales to large networks and efficiently masks buggy behavior.

Second, we argued that breaking the tight coupling between the physical and logical configurations of a network can provide a *single*, general abstraction that simplifies network management. Specifically, we proposed VROOM (Virtual ROuters On the Move), a new network-management primitive where virtual routers can move freely from one physical router to another. We presented the design, implementation, and evaluation of novel migration techniques for virtual routers with either hardware or software data planes. Our evaluation showed that VROOM is transparent to routing protocols and results in no performance impact on the data traffic when a hardware-based data plane is used.

Finally, we introduced the concept of router grafting, and realize an instance of it through BGP session migration. This capability allows an operator to rehome a customer with no disruption, compared to downtimes today measured in minutes. We demonstrated that BGP session migration can be performed in today’s monolithic routing software, without much modification or refactoring of the code. We also demonstrated that with our architecture, BGP session migration can be performed (i) transparently, where the remote BGP session end-point is not modified and is unaware migration is happening, (ii) with minimal impact on other routers not directly involved in the migration, and (iii) such that unplanned routing changes (such as link failures) during the grafting process do not affect correctness, and where packets are delivered successfully even during the migration. We additionally applied

router grafting to traffic engineering where not only can network operators control how traffic flows through the network, but now can also control where traffic enters and exits the network. We developed a new algorithm to determine what links to migrate and through an evaluation using real traffic traces from Internet2 showed that significant improvements in the utilization of the network can be achieved through router grafting.

A commonality among each of our solutions is that rather than solving a problem on top of the existing system, we changed the system to make the problem go away fundamentally. With the bug-tolerant router, rather than test, debug, and analyze router software to reduce bugs, we changed the platform to tolerate the bugs. With VROOM, rather than extend protocols and management practice to minimize disruption, we utilized virtualization in the routers to decouple the logical IP-layer topology from the physical topology. With router grafting, rather than extend protocols, or be forced to settle for coarse-grain migration, we made individual routing sessions migratable. With our application of router grafting to traffic engineering, rather than focusing on optimization of routing on a fixed traffic matrix, we utilized a mechanism which enables us to change the traffic matrix.

Collectively, by taking a unique approach, the contributions of this dissertation enable network operators to perform the desired change on their network without (i) possibly triggering bugs in routers that causes Internet-wide instability, (ii) causing unnecessary network re-convergence events, (iii) having to coordinate with neighboring network operators, or (iv) needing an Internet-wide upgrade to new routing protocols.

## 5.2 A Unified Architecture

Individually, the bug-tolerant router, VROOM, and router grafting each provide an improved router architecture which better accommodates changes in networks. Ideally, however, we want all of these to be realized in a single router. While we prototyped each system independently, there is a clear path to a single unified architecture. As illustrated in Figure 5.1, at a high level each of the bug-tolerant router instances can support router grafting, and each VROOM virtual router can be a bug-tolerant router.

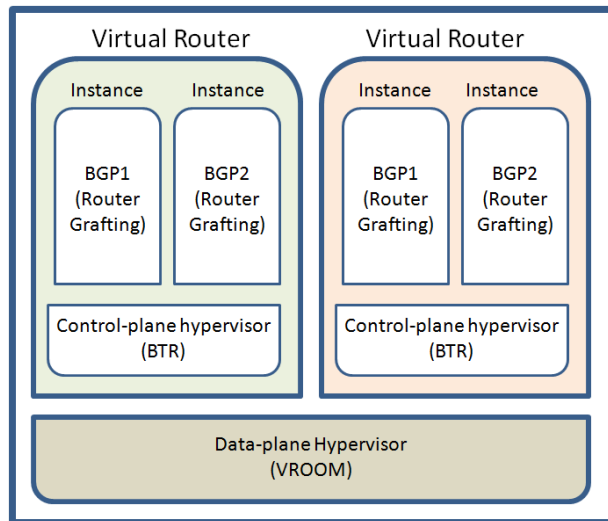

Figure 5.1: Unified architecture.

However, it is not a completely clean separation as there are subtle interactions that need to be addressed. To understand this, we'll first recapitulate the main modifications to router software needed for each:

- **VROOM:** The VROOM hypervisor is based off of virtual machine technology to enable migration of the control plane state and processes. The VROOM hypervisor supports the data plane migration process through data plane cloning. Data plane cloning involves the VROOM hypervisor (i) making a request to the control plane to repopulate the forwarding table and (ii) sending any forward-

ing table updates to both the local forwarding table and the remote forwarding table.

- **BTR:** The BTR hypervisor allows multiple processes to run simultaneously and virtualizes their interface at the socket level, but does not provide complete platform virtualization. The BTR hypervisor (i) intercepts input messages and multicasts them to each instance, (ii) intercepts output messages and performs voting on them before sending out the update, and (iii) manages router instances with the ability to bootstrap new instances and kill buggy instances.
- **Router grafting:** Router grafting requires modifications to the router software to enable the importing and exporting of state, and re-running decision processes based on the new state. Router grafting also requires operating system functionality in order to support the importing and exporting of the state for individual TCP sessions.

From this, we can see that each of the possible interactions requires some modification in order to provide a complete, unified system:

- **VROOM ↔ BTR:** VROOM needs to be able to make a request to the virtual router to repopulate the forwarding table. This is an interface we had to add to the routing software and therefore the BTR hypervisor needs to present this interface. The routing software will still need this interface, and will use the modifications we made originally to enable VROOM. The BTR hypervisor could then simply forward the request from the VROOM hypervisor to each of the router instances. They would each repopulate the forwarding table, which would trigger the BTR hypervisor to vote on each entry before writing the result to the forwarding table.
- **VROOM ↔ Router grafting:** Router grafting needs modifications to the operating system to be able to import/export all of the TCP session state that

is associated with a given socket. The operating system that is providing the socket interface to the routing software processes will need to have this capability. In a container based virtualization solution (e.g., OpenVZ), as we used in our VROOM prototype, the virtual router does not have its own operating system – it shares one with all of the other virtual routers. In a platform virtualization solution (e.g., Xen, KVM, VMWare), the virtual routers will each have their own operating system.

- **BTR ↔ Router grafting:** With router grafting, the router software also had modifications to be able to import and export a socket. In the bug-tolerant router, the routing software actually has sockets that provide a communication channel to the BTR hypervisor and the BTR hypervisor has the sockets that provide a communication channel to neighboring routers. The routing software would not need to change as the communication channel to the BTR hypervisor was hidden from the routing software. The BTR hypervisor would need the ability to import and export a socket, and in turn, trigger an import or export in each of the instances. In addition to importing and exporting a socket, with router grafting the routing session state is also imported and exported along with re-running decision processes based on the updated state. With the bug-tolerant router, there are multiple instances. Therefore, the BTR hypervisor would need to export the state from each instance at the migrate-from router, vote on that state, and then at the migrate-to router import that state in each of the instances. The process will still be transparent to neighboring routers, but as is the case with a bug-tolerant router, with multiple instances there will be more processing to perform a session migration.

## 5.3 Future Work

In addition to building the unified architecture, each individual system has directions for future research. Here, we examine a few of these.

### 5.3.1 Monitoring in Addition to Voting for a Bug-Tolerant Router

With the bug-tolerant router we perform voting among multiple instances of routing software performing the same functionality to detect and correct any bugs. A buggy instance of the software can be rebooted or replaced. A complementary approach would be to utilize techniques which perform anomaly detection on the run-time characteristics of the software itself [96] – e.g., memory utilization, CPU utilization, latency. By detecting something is going wrong (e.g., CPU utilization is spiking without a flood of updates to process) we may be able to catch buggy instances before they become faulty. This proactive correction of instances will lead to a more reliable system.

### 5.3.2 Hosted and Shared Network Infrastructure with VROOM

In the world of computing, a shift has begun towards the use of infrastructures which are hosted and shared (i.e., cloud computing). This has increased the level of innovation by enabling companies to come out with new web services for less cost, created new business models where a party can lease out slices of servers on demand with a pay-per-use model, and even simplified management in private (non-hosted) networks by enabling a company to more easily run independent services on its own servers. We believe that the same will be true of networking where many applications would

greatly benefit from in-network functionality beyond the basic connectivity offering of today.

A key challenge that these infrastructures present is that they decouple the owner of the infrastructure from the service provider that is running the routing protocols and applications. Not only would planned maintenance be disruptive, as in networks today, but techniques which lessen the impact (e.g., diverting traffic away) are no longer possible since these are two different parties. VROOM provides a solution here as it decouples physical from logical, so physical maintenance can be done without impacting logical. Isolation is also important, which has been examined in the computing context [66], as well as the virtual router context [22]. We view a router as more than just routing protocols, so both will be relevant.

### 5.3.3 Router Grafting for Security

Router grafting is a mechanism to seamlessly move links and the associated BGP session. This not only aids in today’s network management, it enables new applications. We applied router grafting to traffic engineering, but there may be other novel uses of the technology that are worth exploring. One promising application area is to use router grafting as part of a “moving-target” defense mechanism [53]. Static systems allow attackers to observe the operation of the system over long periods of time and plan attacks with confidence. With a moving-target defense, the system is continuously changed so that the planned attack will no longer work. By utilizing router grafting, we can continuously change the topology and change which router (different vendors, different models) a particular neighboring network is connected to.

## 5.4 Concluding Remarks

The Internet is becoming critical infrastructure. As such, we need a network infrastructure that we can depend on. We took an approach which does not require an Internet-wide upgrade, yet improved the reliability of the network. By rethinking the design of routers, we enable network operators to manage their networks without triggering much of the disruption that is seen today when performing this management. We utilized software and data diversity to build a router which operates correctly even in the inevitable presence of bugs. We introduced novel migration mechanism, both at the granularity of a virtual router and at the level of an individual link and associated routing session. Not only does this migration simplify today's management tasks, it also enables new applications as well.

Perhaps most importantly, we have shown that significant improvements can be made without having to wipe the slate clean in the Internet. We do this by capitalizing on recent trends in networks and routers to rethink the router design to better accommodate the changes network operators routinely need to make. We believe that our work is an important step towards a more reliable Internet and provide a novel approach to challenges faced in network management. Finally, this work raises interesting questions about what exactly a router is, and the various ways routers can be “sliced and diced.” We plan to explore these questions in our ongoing work.

# Bibliography

- [1] BIRD Internet routing daemon. <http://bird.network.cz/>.
- [2] Cisco 7200 simulator. (software to run Cisco IOS images on desktop PCs) [www.ipflow.utc.fr/index.php/Cisco\\_7200\\_Simulator](http://www.ipflow.utc.fr/index.php/Cisco_7200_Simulator).
- [3] Cisco IOS high availability curbs downtime with faster reloads and upgrades. [http://www.cisco.com/en/US/products/ps6550/prod\\_white\\_papers\\_list.html](http://www.cisco.com/en/US/products/ps6550/prod_white_papers_list.html).
- [4] Olive. (software to run Juniper OS images on desktop PCs) [juniper.cluepon.net/index.php/Olive](http://juniper.cluepon.net/index.php/Olive).
- [5] OpenVZ. <http://www.openvz.org>.
- [6] Quagga software routing suite. <http://www.quagga.net>.
- [7] Route views project. [www.routeviews.org](http://www.routeviews.org).
- [8] Vyatta (open-source router vendor). [www.vyatta.com](http://www.vyatta.com).
- [9] XORP: Open Source IP Router. <http://www.xorp.org>.
- [10] IETF draft: MRT routing information export format, July 2009. <http://tools.ietf.org/id/draft-ietf-grow-mrt-10.txt>.
- [11] The Internet2 Network. <http://www.internet2.edu/>.
- [12] T. Afferton, R. Doverspike, C. Kalmanek, and K. K. Ramakrishnan. Packet-aware transport for metro networks. *IEEE Communication Magazine*, March 2004.
- [13] S. Agarwal, C. Chuah, S. Bhattacharyya, and C. Diot. Impact of BGP dynamics on router CPU utilization. In *Passive and Active Measurement*, April 2004.
- [14] Mukesh Agrawal, Susan Bailey, Albert Greenberg, Jorge Pastor, Panagiotis Sebos, Srinivasan Seshan, Jacobus van der Merwe, and Jennifer Yates. Router-Farm: Towards a dynamic, manageable network edge. In *ACM SIGCOMM Workshop on Internet Network Management (INM)*, September 2006.

- [15] C. Alaettinoglu, V. Jacobson, and H. Yu. Towards millisecond IGP convergence. In *IETF Draft*, November 2000.
- [16] R. Alimi, Y. Wang, and Y. R. Yang. Shadow configuration as a network management primitive. In *SIGCOMM*, August 2008.
- [17] David G. Andersen, Hari Balakrishnan, M. Frans Kaashoek, and Robert Morris. Resilient overlay networks. In *Proc. ACM SOSP*, October 2001.
- [18] D. Applegate, L. Breslau, and E. Cohen. Coping with network failures: Routing strategies for optimal demand oblivious restoration. In *Proc. ACM SIGMETRICS*, June 2004.
- [19] Hitesh Ballani, Paul Francis, Tuan Cao, and Jia Wang. Making Routers Last Longer with ViAggre. In *Proc. of USENIX Symposium on Networked Systems Design and Implementation*, April 2009.
- [20] E. Berger and B. Zorn. DieHard: Probabilistic memory safety for unsafe languages. In *Programming Languages Design and Implementation*, June 2006.
- [21] Massimo Bernaschi, Francesco Casadei, and Paolo Tassotti. SockMi: a solution for migrating TCP/IP connections. In *Proc. Euromicro International Conference on Parallel, Distributed and Network-Based Processing*, 2007.
- [22] Sapan Bhatia, Murtaza Motiwala, Wolfgang Muehlbauer, Yogesh Mundada, Vytautas Valancius, Andy Bavier, Nick Feamster, Larry Peterson, and Jennifer Rexford. Trellis: A platform for building flexible, fast virtual networks on commodity hardware. In *Proc. Workshop on Real Overlays and Distributed Systems (ROADS)*, December 2008.
- [23] Olivier Bonaventure, Clarence Filisfilis, and Pierre Francois. Achieving sub-50 milliseconds recovery upon BGP peering link failures. *IEEE/ACM Trans. Networking*, October 2007.
- [24] Robert Braden. Requirements for Internet Hosts - Communication Layers. RFC 1122, October 1989.
- [25] B. Brenner. Cisco IOS flaw prompts symantec to raise threat level. In *Information Security Magazine*, Sept. 2005.
- [26] S. Bryant and P. Pate. Pseudo wire emulation edge-to-edge (PWE3) architecture. RFC 3985, March 2005.
- [27] J. Caballero, T. Kampouris, D. Song, and J. Wang. Would diversity really increase the robustness of the routing infrastructure against software defects? In *NDSS*, Feb. 2008.
- [28] M. Caesar, D. Caldwell, N. Feamster, J. Rexford, A. Shaikh, and K. van der Merwe. Design and implementation of a routing control platform. In *NSDI*, April 2005.

- [29] M. Caesar and J. Rexford. Building bug-tolerant routers with virtualization. In *PRESTO*, August 2008.
- [30] M. Castro and B. Liskov. Practical byzantine fault tolerance. In *OSDI*, February 1999.
- [31] Joe Chabarek, Joel Sommers, Paul Barford, Cristian Estan, David Tsiang, and Steve Wright. Power awareness in network design and routing. In *IEEE INFOCOM*, 2008.
- [32] E. Chen, R. Fernando, J. Scudder, and Y. Rekhter. Graceful Restart Mechanism for BGP. RFC 4724, January 2007.
- [33] B-G. Chun, P. Maniatis, and S. Shenker. Diverse replication for single-machine byzantine-fault tolerance. In *USENIX Annual Technical Conference*, June 2008.
- [34] Ciena CoreDirector Switch. <http://www.ciena.com>.
- [35] Cisco ASR 1000 series aggregation services router high availability: Delivering carrier-class services to midrange router. [http://www.cisco.com/en/US/prod/collateral/routers/ps9343/solution\\_overview\\_c22-450809\\_ps9343\\_Product\\_Solution\\_Overview.html](http://www.cisco.com/en/US/prod/collateral/routers/ps9343/solution_overview_c22-450809_ps9343_Product_Solution_Overview.html).
- [36] MPLS VPN Carrier Supporting Carrier. [http://www.cisco.com/en/US/docs/ios/12\\_0st/12\\_0st14/feature/guide/csc.html](http://www.cisco.com/en/US/docs/ios/12_0st/12_0st14/feature/guide/csc.html).
- [37] Cisco Logical Routers. [http://www.cisco.com/en/US/docs/ios\\_xr\\_sw/iosxr\\_r3.2/interfaces/command/reference/hr32lr.html](http://www.cisco.com/en/US/docs/ios_xr_sw/iosxr_r3.2/interfaces/command/reference/hr32lr.html).
- [38] Christopher Clark, Keir Fraser, Steven Hand, Jacob Gorm Hansen, Eric Jul, Christian Limpach, Ian Pratt, and Andrew Warfield. Live Migration of Virtual Machines. In *NSDI*, May 2005.
- [39] B. Cox, D. Evans, A. Filip, J. Rowanhill, W. Hu, J. Davidson, J. Knight, A. Nguyen-Tuong, and J. Hiser. N-variant systems: A secretless framework for security through diversity. In *Usenix Security*, August 2006.
- [40] Brendan Cully, Geoffrey Lefebvre, Dutch Meyer, Mike Feeley, Norm Hutchinson, and Andrew Warfield. Remus: High availability via asynchronous virtual machine replication. In *NSDI*, April 2008.
- [41] D-ITG. <http://www.grid.unina.it/software/ITG/>.
- [42] J. Duffy. BGP bug bites Juniper software. In *Network World*, December 2007.
- [43] A. Elwalid, C. Jin, S. Low, and I. Widjaja. MATE: MPLS adaptive traffic engineering. In *Proc. IEEE INFOCOM*, 2001.
- [44] Emulab. <http://www.emulab.net>.

- [45] J. Evers. Trio of Cisco flaws may threaten networks. In *CNET News*, January 2007.
- [46] N. Feamster and H. Balakrishnan. Detecting BGP configuration faults with static analysis. In *NSDI*, May 2005.
- [47] N. Feamster and J. Rexford. Network-wide prediction of BGP routes. In *IEEE/ACM Trans. Networking*, April 2007.
- [48] Nick Feamster, Lixin Gao, and Jennifer Rexford. How to lease the Internet in your spare time. *ACM SIGCOMM Computer Communications Review*, Jan 2007.
- [49] Bernard Fortz and Mikkel Thorup. Internet traffic engineering by optimizing OSPF weights. In *Proc. IEEE INFOCOM*, 2000.
- [50] Pierre Francois and Olivier Bonaventure. Avoiding transient loops during the convergence of link-state routing protocols. *IEEE/ACM Transactions on Networking*, 15(6):1280–1932, December 2007.
- [51] Pierre Francois, Pierre-Alain Coste, Bruno Decraene, and Olivier Bonaventure. Avoiding disruptions during maintenance operations on BGP sessions. *IEEE Transactions on Network and Service Management*, 4(3):1–11, 2007.
- [52] Pierre Francois, Mike Shand, and Olivier Bonaventure. Disruption-free topology reconfiguration in OSPF networks. In *IEEE INFOCOM*, May 2007.
- [53] Anup K. Ghosh, Dimitrios Pendarakis, and William H. Sanders. National cyber leap year summit 2009 co-chairs report: Moving target defense. [http://www.qinetiq-na.com/Collateral/Documents/English-US/InTheNews\\_docs/National\\_Cyber\\_Leap\\_Year\\_Summit\\_2009\\_Co-Chairs\\_Report.pdf](http://www.qinetiq-na.com/Collateral/Documents/English-US/InTheNews_docs/National_Cyber_Leap_Year_Summit_2009_Co-Chairs_Report.pdf).
- [54] Joel Gottlieb, Albert Greenberg, Jennifer Rexford, and Jia Wang. Automated provisioning of BGP customers. *IEEE Network Magazine*, November/December 2003.
- [55] Timothy G. Griffin and João Luís Sobrinho. Metarouting. In *SIGCOMM*, August 2005.
- [56] D. Gupta, S. Lee, M. Vrable, S. Savage, A. Snoeren, A. Vahdat, G. Varghese, and G. Voelker. Difference engine: Harnessing memory redundancy in virtual machines. In *OSDI*, December 2008.
- [57] Maruti Gupta and Suresh Singh. Greening of the Internet. In *SIGCOMM*, August 2003.
- [58] R. Hinden. Virtual router redundancy protocol (VRRP). RFC 3768, April 2004.

- [59] G. Iannaccone, C.-N. Chuah, S. Bhattacharyya, and C. Diot. Feasibility of IP restoration in a tier-1 backbone. *IEEE Network Magazine*, Mar 2004.
- [60] Internet2. <http://www.internet2.org>.
- [61] Juniper Logical Routers. <http://www.juniper.net/techpubs/software/junos/junos85/feature-guide-85/id-11139212.html>.
- [62] F. Junqueira, R. Bhgwan, A. Hevia, K. Marzullo, and G. Voelker. Surviving Internet catastrophes. In *HotOS*, May 2003.
- [63] S. Kandula, D. Katabi, B. Davie, and A. Charny. Walking the tightrope: Responsive yet stable traffic engineering. In *Proc. SIGCOMM*, 2005.
- [64] Ethan Katz-Bassett, Harsha V. Madhyastha, John P. John, Arvind Krishnamurthy, David Wetherall, and Thomas Anderson. Studying black holes in the internet with hubble. In *Proceedings of the 5th USENIX Symposium on Networked Systems Design and Implementation*, NSDI'08, 2008.
- [65] Eric Keller, Jennifer Rexford, and Jacobus van der Merwe. Seamless BGP session migration with router grafting. In *Proc. Networked Systems Design and Implementation*, 2010.
- [66] Eric Keller, Jakub Szefer, Jennifer Rexford, and Ruby B. Lee. NoHype: Virtualized cloud infrastructure without the virtualization. In *International Symposium on Computer Architecture*, June 2010.
- [67] Eric Keller, Minlan Yu, Matthew Caesar, , and Jennifer Rexford. Virtually eliminating router bugs. In *CoNEXT*, Dec 2009.
- [68] Z. Kerravala. Configuration Management Delivers Business Resiliency. The Yankee Group, November 2002.
- [69] Gerwin Klein, Kevin Elphinstone, Gernot Heiser, June Andronick, David Cock, Philip Derrin, Dhammika Elkaduwe, Kai Engelhardt, Rafal Kolanski, Michael Norrish, Thomas Sewell, Harvey Tuch, and Simon Winwood. sel4: Formal verification of an os kernel. In *Proceedings of the 22nd ACM Symposium on Operating Systems Principles (SOSP)*, 2009.
- [70] J. Knight and N. Leveson. A reply to the criticisms of the Knight & Leveson experiment. *ACM SIGSOFT Software Engineering Notes*, January 1990.
- [71] W. Knight. Router bug threatens 'Internet backbone'. In *New Scientist Magazine*, July 2003.
- [72] E. Kohler, R. Morris, B. Chen, J. Jannotti, and M. Kaashoek. The Click modular router. In *ACM Trans. Comp. Sys.*, August 2000.

- [73] Michael A. Kozuch, Michael Kaminsky, and Michael P. Ryan. Migration without virtualization. In *Proc. Workshop on Hot Topics in Operating Systems*, May 2009.
- [74] A. Kuate, R. Teixeira, and M. Meulle. Characterizing network events and their impact on routing. In *CoNEXT (Student Poster)*, December 2007.
- [75] K. Lakshminarayanan, M. Caesar, M. Rangan, T. Anderson, S. Shenker, and I. Stoica. Achieving convergence-free routing using failure-carrying packets. In *SIGCOMM*, August 2007.
- [76] A. Markopoulou, G. Iannacone, S. Bhattacharrya, C-N. Chuah, and C. Diot. Characterization of failures in an IP backbone. In *IEEE/ACM Trans. Networking*, Oct. 2008.
- [77] Marvin McNett, Diwaker Gupta, Amin Vahdat, and Geoffrey M. Voelker. Usher: An extensible framework for managing clusters of virtual machines. In *USENIX Large Installation System Administration Conference (LISA)*, November 2007.
- [78] M. Motiwala, M. Elmore, N. Feamster, and S. Vempala. Path splicing. In *SIGCOMM*, 2008.
- [79] NetFPGA. <http://yuba.stanford.edu/NetFPGA/>.
- [80] A. O'Donnell and H. Sethu. On achieving software diversity for improved network security using distributed coloring algorithms. In *ACM CCS*, October 2004.
- [81] Average retail price of electricity. [http://www.eia.doe.gov/cneaf/electricity/epm/table5\\_6\\_a.html](http://www.eia.doe.gov/cneaf/electricity/epm/table5_6_a.html).
- [82] L. Qiu, Y. R. Yang, Y. Zhang, and S. Shenker. Selfish routing in Internet-like environments. In *Proc. SIGCOMM*, 2003.
- [83] R. Rajendran, V. Misra, and D. Rubenstein. Theoretical bounds on control-plane self-monitoring in routing protocols. In *SIGMETRICS*, June 2007.
- [84] M. Reardon. Cisco offers justification for Procket deal. June 2004. [http://news.cnet.com/Cisco-offers-justification-for-Procket-deal/2100-1033\\_3-5237818.html](http://news.cnet.com/Cisco-offers-justification-for-Procket-deal/2100-1033_3-5237818.html).
- [85] Y. Rekhter and T. Li. A border gateway protocol 4 (bgp-4). RFC 1771, March 1995.
- [86] Renesys. AfNOG takes byte out of Internet. <http://www.renesys.com/blog/2009/05/byte-me.shtml>.
- [87] Renesys. House of cards. <http://www.renesys.com/blog/2010/08/house-of-cards.shtml>.

- [88] Renesys. How to build a cybernuke. <http://www.renesys.com/blog/2010/04/how-to-build-a-cybernuke.shtml>.
- [89] Renesys. Longer is not always better. <http://www.renesys.com/blog/2009/02/longer-is-not-better.shtml>.
- [90] A. Rostami and E.H. Sargent. An optical integrated system for implementation of NxM optical cross-connect, beam splitter, mux/demux and combiner. *IJCSNS International Journal of Computer Science and Network Security*, July 2006.
- [91] Kurt Roth, Fred Goldstein, and Jonathan Kleinman. Energy Consumption by Office and Telecommunications Equipment in commercial buildings Volume I: Energy Consumption Baseline. National Technical Information Service (NTIS), U.S. Department of Commerce, Springfield, VA 22161, NTIS Number: PB2002-101438, 2002.
- [92] Stefan Savage, Tom Anderson, Amit Aggarwal, David Becker, Neal Cardwell, Andy Collins, Eric Hoffman, John Snell, Amin Vahdat, Geoff Voelker, and John Zahorjan. Detour: A case for informed Internet routing and transport. *IEEE Micro*, January 1999.
- [93] Aman Shaikh, Rohit Dube, and Anujan Varma. Avoiding instability during graceful shutdown of multiple OSPF routers. *IEEE/ACM Trans. Networking*, 14(3):532–542, June 2006.
- [94] Alex Snoeren and Hari Balakrishnan. An end-to-end approach to host mobility. In *Proc. ACM MOBICOM*, Boston, MA, August 2000.
- [95] Mobeen Tahir, Mark Ghattas, Dawit Birhanu, and Syed Natif Nawaz. *Cisco IOS XR Fundamentals*. Cisco Press, 2009.
- [96] Yongmin Tan and Xiaohui Gu. On predictability of system anomalies in real world. In *18th Annual Meeting of the IEEE International Symposium on Modeling, Analysis and Simulation of Computer and Telecommunication Systems (MASCOTS 2010)*, 2010.
- [97] R. Teixeira, T. Griffin, A. Shaikh, and G. Voelker. Network sensitivity to hot-potato disruptions. In *Proc. SIGCOMM*, 2003.
- [98] Renata Teixeira, Aman Shaikh, Tim Griffin, and Jennifer Rexford. Dynamics of hot-potato routing in IP networks. In *SIGMETRICS*, June 2004.
- [99] J.E. van der Merwe and I.M. Leslie. Switchlets and dynamic virtual ATM networks. In *Proc. IFIP/IEEE International Symposium on Integrated Network Management*, May 1997.
- [100] VINI. <http://www.vini-veritas.net/>.

- [101] Hao Wang, Haiyong Xie, Lili Qiu, Yang Richard Yang, Yin Zhang, and Albert Greenberg. COPE: Traffic engineering in dynamic networks. In *Proc. SIGCOMM*, 2006.
- [102] L. Wang, D. Massey, K. Patel, and L. Zhang. FRTR: A scalable mechanism to restore routing table consistency. In *DSN*, June 2004.
- [103] Y. Wang, E. Keller, B. Biskeborn, J. van der Merwe, and J. Rexford. Virtual Routers on the Move: Live Router Migration as a Network-Management Primitive. In *SIGCOMM*, August 2008.
- [104] John Wei, K.K. Ramakrishnan, Robert Doverspike, and Jorge Pastor. Convergence through packet-aware transport. *Journal of Optical Networking*, 5(4), April 2006.
- [105] B. White, J. Lepreau, L. Stoller, R. Ricci, G. Guruprasad, M. Newbold, M. Hibler, C. Barb, and A. Joglekar. An integrated experimental environment for distributed systems and networks. In *OSDI*, December 2002.
- [106] Timothy Wood, Prashant Shenoy, Arun Venkataramani, and Mazin Yousif. Black-box and Gray-box Strategies for Virtual Machine Migration. In *NSDI*, April 2007.
- [107] Z. Yin, M. Caesar, and Y. Zhou. Towards understanding bugs in router software. In *ACM SIGCOMM Computer Communication Review*, June 2010.
- [108] A. Yumerefendi, B. Mickle, and L. Cox. Tightlip: Keeping applications from spilling the beans. In *NSDI*, April 2007.
- [109] C. Zhang, Z. Ge, J. Kurose, Y. Liu, and D. Towsley. Optimal routing with multiple traffic matrices: Tradeoff between average case and worst case performance. In *Proc. International Conference on Network Protocols*, Nov. 2005.
- [110] Y. Zhang, S. Dao, H. Vin, L. Alvisi, and W. Lee. Heterogeneous networking: A new survivability paradigm. In *New Security Paradigms Workshop*, September 2008.
- [111] Y. Zhou, D. Marinov, W. Sanders, C. Zilles, M. d'Amorim, S. Lauterburg, and R. Lefever. Delta execution for software reliability. In *Hot Topics in Dependability*, June 2007.